

Eccentric Screw Pumps Series AE.N, AEB.N, AE.H, AEB.H Design ZD, ZE

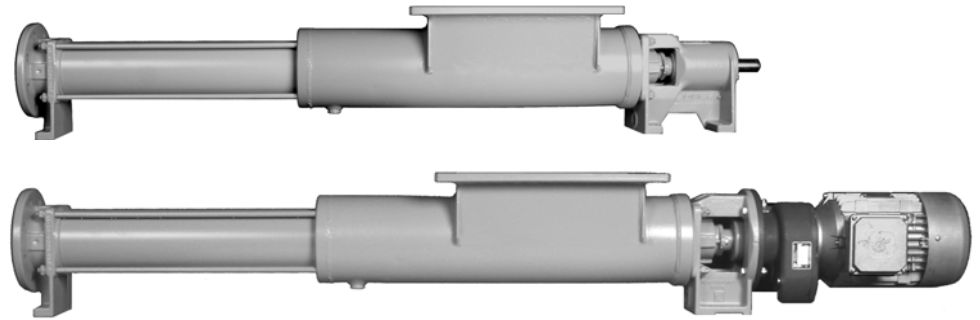

Applications

These pumps are used to move products that are no longer free-flowing as well as highly viscous, neutral or aggressive, purified, abrasive, or gaseous products, even those that contain fibrous or solid components.

They are commonly used in wastewater and clarification plants, the chemical, paper and cellulose, soap and grease, paint and coatings, food and beverage, plastics, and ceramics industries as well as in agriculture and in sugar processing, among others.

Function

Self-priming, rotating displacement pump. The pumping elements are the rotor, the fixed stator, and the feeding screw. The rotor and stator contact each other at two points on a cross section. When viewed over the length of the pumping elements, these two points form two sealing lines. As the rotor turns, the contents located in the resulting sealed chambers are moved axially and fully continuously from the suction to the pressure side of the pump. Despite rotation of the rotor, no turbulence results. The consistent chamber volumes eliminate crushing forces and ensure an extremely gentle, low-pulse pumping action.

Structural design

ZD-design pumps use a bearing bracket, while ZE-design pumps employ a block design.

The pressure housing, stator, and plug casing are held together by means of external housing connection screws (clamp bolts).

All pump sizes have an inlet hopper on the suction housing. The right-angle connection flange is provided as a means of attaching filling funnels. The oversized feeding screw is dimensioned to ensure reliable filling of the pumping elements (over the plug area).

The stator is vulcanized into a pipe or barrel casing (uniform elastomer wall thickness) and is equipped on both sides with external collars that provide reliable sealing with the suction and pressure housings and protect the stator casing from corrosion.

The exchangeable stuffing box or mechanical seal housing (can be converted later to another seal type) is located between the suction housing and the bearing bracket or lantern base.

Shaft seal

The shaft is sealed by means of uncooled, cooled, or heated packing stuffing boxes or by means of uncooled or cooled, maintenance-free, unbalanced, single or double-acting mechanical seals. Material pairing and construction are adapted to the respective operating conditions.

The stuffing box or mechanical seal housing for the various shaft seal types are interchangeable within a consistent size. The various mechanical seal housing parts form a modular system and can be easily combined with each other if the pump is ever converted to another type of mechanical seal.

Installation space for mechanical seals according to DIN 24 960 (excepting double mechanical seals).

See pages 4, 5, and 6 for more information.

Bearings on the ZE design

The bearing of the drive/plug-in shaft is provided in the reinforced bearings of the gear motors or adjustable gear, which simultaneously absorb any axial forces.

Since the drives are only delivered with reinforced bearings, the customer can confidently run up the respective pumps within the permissible operational limits.

Bearings on the ZD design

The drive shaft bearing is in the bearing bracket. The drive torque is transferred over the drive shaft and the universal joint shaft to the rotor.

Since the entire bearing unit can be pulled off of the drive shaft without requiring further disassembly of the pump, the shaft seal housings are easily accessible.

Universal joints

Both ends of the universal joint shaft end in liquid-sealed encapsulated pin joints that are designed to be very simple and robust. As a result, they can flawlessly absorb the rotor's exocentric movement.

Drive on the ZE design

The drive can take the form of non-explosion-proof or explosion-proof drive motors or adjustable gears. See page 27 for the drive options. For specifications and dimensions, see the separate sales literature, sheet 19-00-0000-111-3.

A major benefit is that each design size has consistent connection dimensions for all drive types. This makes it very easy to convert to a new drive type or size at a later time.

Drive on the ZD design

See page 27 for the drive options.
 Drives from any manufacturer can be used. Refer to the manufacturer's documentation for technical specifications and dimensions.

Setting up the pump

The pumps are set up horizontally.
 In the ZD design, the pump and the drive are connected together by means of an elastic coupling or an intermediate gear (usually a V-belt drive) and are mounted onto a shared base plate. Group dimensions available upon request.

Exchangeability of parts

The components of all progressing cavity pumps are designed to be modular. As a result, a customer who employs several pumps from various series and designs will be able to maintain a simple and cost-effective stock of reserve parts.

Technical specifications

Please refer to the diagram on page 3 or the separate individual diagrams for data on pump capacities, permissible speed ranges, and required drives.

Series	AEB1N		AEB1N		AEB2N		AE1N		AE1N		AE2N		AE2N	
Size	25 ... 1450		100 ... 1450		25 ... 1450		25 ... 5000		100 ... 5000		25 ... 5000		100 ... 1450	
Design variation														
G = Stator with uniform elastomer wall thickness			G						G				G	
Pump capacity	Q	l/min	up to	750	750	750	1700	1700	1700	1700	1700	750	750	750
Temperature of pumped liquid	t	°C ①	up to	100	100	100	150	150	150	150	150	150	150	150
Pump pressure	Δp	bar	up to	6	12	12	6	12	12	12	12	18 ③	18 ③	18 ③
Max. pump pressure	p _d	bar	up to	6	12	12	6	12	12	12	12	18	18	18
Achievable underpressure	p _s	bar②	up to	0,5										
Viscosity	η	mPa·s ②	up to	1.000.000										
Permissible proportion of solids	Vol%	②	up to	95										
Proportion of dry substances	%	②	up to	38										
Permissible housing pressure, suction housing	p _z	bar	up to	0,5										

Series	AEB4H		AE1+1H		AE2H		AE2+2H		AE2+2H		AE4H	
Size	25 ... 50		2700		100 ... 1450		100 ... 2700		100 ... 1450		25 ... 1450	
Design variation												
G = Stator with uniform elastomer wall thickness			G		G				G			
Pump capacity	Q	l/min	up to	55	1000	750	1000	750	750	750	750	750
Temperature of pumped liquid	t	°C ①	up to	100	150	150	150	150	150	150	150	150
Pump pressure	Δp	bar	up to	24	24	24	24	36 ④	24	24	36 ④	24
Max. pump pressure	p _d	bar	up to	24	24	24	24	36	24	24	36	24
Achievable underpressure	p _s	bar②	up to	0,5								
Viscosity	η	mPa·s ②	up to	1.000.000								
Permissible proportion of solids	Vol%	②	up to	95								
Proportion of dry substances	%	②	up to	38								
Permissible housing pressure, suction housing	p _z	bar	up to	0,5								

The specified performance data are intended to provide only an overview of the product and its performance! Refer to the respective proposal and order confirmation for exact operational limits.

Maximum permissible grain sizes and fiber lengths

Size	25	50	100	200	380	750	1450	2700	5000	
Max. grain size	mm	2,5	3	3,8	5	6,8	9,5	14	20	25
Max. fiber length	mm	42	42	48	60	79	98	130	210	250

The pump speed must be reduced as the proportion of solids in the liquid and the grain size increase.

- ① depending on the pumped liquid and the elastomers that are used.
- ② depending on pump size/design, speed, liquid pumped
- ③ 12 bar when shaft has sleeve.
- ④ 24 bar when shaft has sleeve.

Performance graph

Used for rough selection of the pump size and rotational speed in dependence of the desired flow rate and the type of liquid being pumped. V_g "m" = average running speed of the rotor in the stator.

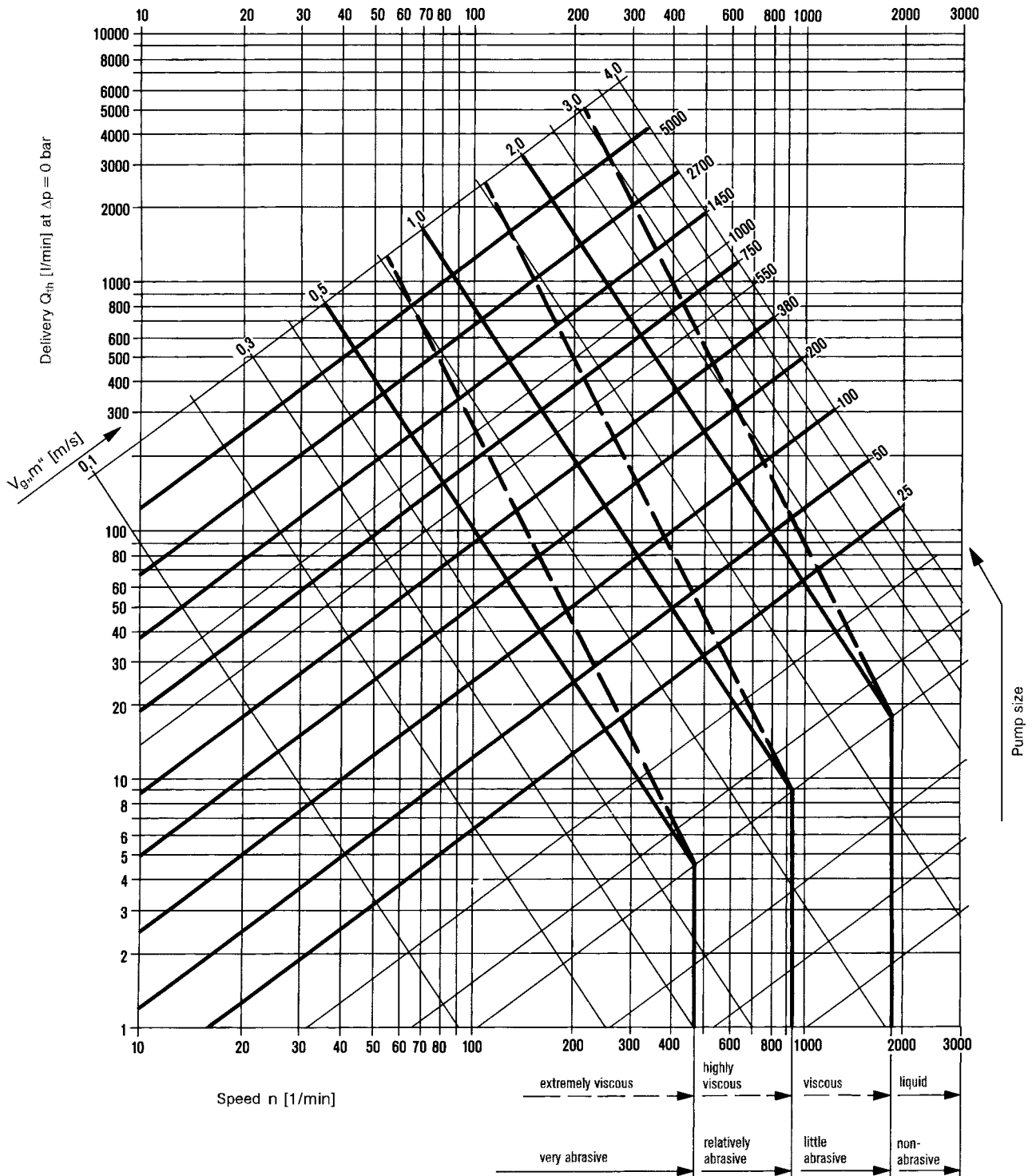

Sizes of the series AE.N, AE.H, design ZD, ZE. Refer to the reverse side of this brochure or the individual brochures of the other series for data on the performance range not covered by pumps of these series. See individual characteristic curves for precise performance data.

Type key

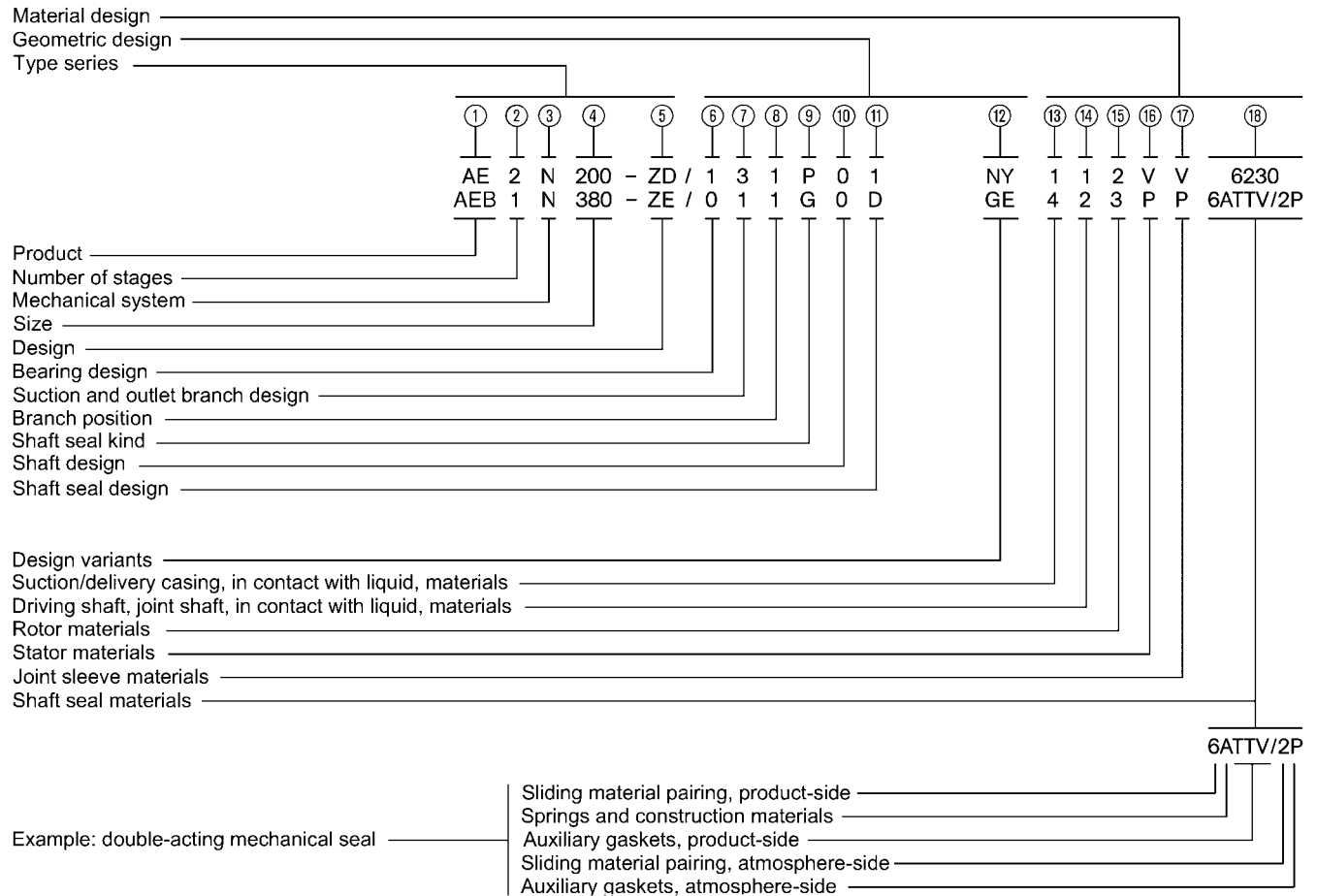

Explanations for the type key:

Position in type key	Designation	Version
①	Product	ALLWEILER progressing cavity pump
②	Number of stages	1 = single-stage 1+1 = single-stage + single-stage 2 = double-stage 2+2 = double-stage + double-stage 4 = four-stage See the specifications on page 2 for assignment of the sizes and pumping pressures.
③	Mechanical system	N, H
④	Size	Possible sizes: 25, 50, 100, 200, 380, 750, 1450, 2700, 5000 The figures indicate the theoretical flow rate in liters/min. at n = 400 1/min and Δp = 0 bar.
⑤	Design	ZD = Feeding-screw type with internal bearings ZE = Feeding-screw type with external bearings
⑥	Bearing design	1 = Hoseproof, radial bearing on drive side with sealing washer, axial bearing on the pump side with shaft sealing ring. Both bearings can be regreased. For horizontal alignment 0 = External bearing in drive unit
⑦	Suction and outlet branch design	1 = Pressure port DIN flange } and inlet hopper according to dimension sheet, pages 13 to 21 3 = Pressure port ANSI flange } X = Pressure port DIN 2501, PN 25; ANSI B 16.1. Class 250 and ANSI B 16.5. Class 300 (on pumps with N mechanics) inlet hopper and/or pressure port in special version.
⑧	Branch position	1 = Upper filling funnel opening
⑨	Shaft seal kind	P = Packing stuffing box or other non-mechanical shaft seal G = Mechanical seal

⑩	Shaft design	0 = Shaft without sleeve 1 = Shaft with sleeve (not possible on size 25 and N mechanics)												
⑪	Shaft seal type	Stuffing boxes P01/P11 = Stuffing boxes in normal version (without seal chamber ring/without flush ring) P02/P12 = Stuffing box with flushing ring P03/P13 = Stuffing box with internal seal chamber ring P04/P14 = Stuffing box with external seal chamber ring P0X/P1X = Non-mechanical shaft seal in a special version <hr/> Mechanical seals: (X = version is possible) for pump size (H mechanical system) 25 50 100 200 380 750 1450 2700 for pump size (N mechanical system) 25 50 100 200 380 750 1450 2700 5000 Shaft diameter at location of shaft seal 25 30 35 43 53 60 75 90 110 G0K = Single mech. seal, DIN 24 960, K version, U shape ①X X X X X X X X X ② G0N = like previous, but N version ①X X X X X X X X X - G0S = Single mech. seal, DIN 24 960, K version, U shape, rotating part with integrated locking option and pump-side throttle ring. ①X X X X X X X X X ② G0T = like previous, but N version ①X X X X - X X - - G0Q = Single mech. seal, DIN 24 960, K version, U shape with quench ①X X X X X X X X X ② G0D = double mechanical seal ①② ② ② ② ② ② ② ② ② G0X = Mechanical seal in special version <hr/> ① not available with shaft sleeve ② discussion required about seal type												
⑫	Design variants	<table border="0"> <tr> <td style="vertical-align: top;"> Stators with non-uniform elastomer wall thicknesses (all grades) N M H T </td> <td style="vertical-align: middle; padding: 0 10px;">} Rotor with temperature play depending on the temperature of the pumped liquid.</td> <td style="vertical-align: top;"> Stators with uniform elastomer wall thicknesses (all grades) D E F R </td> <td style="vertical-align: middle; padding: 0 10px;">} Rotor with temperature play depending on the temperature of the pumped liquid.</td> </tr> <tr> <td>Y =</td> <td>Rotor ductile hard chromed</td> <td>G =</td> <td>Stator with uniform elastomer wall thickness</td> </tr> <tr> <td>Z =</td> <td>Rotor metallic coated</td> <td>X =</td> <td>Other versions</td> </tr> </table>	Stators with non-uniform elastomer wall thicknesses (all grades) N M H T	} Rotor with temperature play depending on the temperature of the pumped liquid.	Stators with uniform elastomer wall thicknesses (all grades) D E F R	} Rotor with temperature play depending on the temperature of the pumped liquid.	Y =	Rotor ductile hard chromed	G =	Stator with uniform elastomer wall thickness	Z =	Rotor metallic coated	X =	Other versions
Stators with non-uniform elastomer wall thicknesses (all grades) N M H T	} Rotor with temperature play depending on the temperature of the pumped liquid.	Stators with uniform elastomer wall thicknesses (all grades) D E F R	} Rotor with temperature play depending on the temperature of the pumped liquid.											
Y =	Rotor ductile hard chromed	G =	Stator with uniform elastomer wall thickness											
Z =	Rotor metallic coated	X =	Other versions											
⑬	Suction/delivery housing in contact fluid, materials	1 = EN-GJL-250 / EN-GJS-400-15/ St. 4 = 1.4408/1.4571 X = special materials												
⑭	Driving shaft, plug-in shaft, joint shaft contact liquid, material	1 = 1.4021/1.4571 2 = 1.4301/1.4571/1.4462 4 = 1.4571/1.4462 X = special materials, such as on universal joint parts												
⑮	Rotor materials	2 = 1.4301 4 = 1.4571 3 = 1.2436/1.2379 X = special materials, like other metals, plastics												
⑯	Stator materials	<table border="0"> <tr> <td style="vertical-align: top;"> WB = natural rubber, soft P = acrylonitrile-butadiene rubbers (NBR) PL = acrylonitrile-butadiene rubbers (NBR) N = polychloroprene (N) Y = chlorosulfonated polyethylene (CSM) </td> <td style="vertical-align: top;"> YL = chlorosulfonated polyethylene (CSM) V = fluoroelastomer (FPM) HP = acrylonitrile-butadiene rubbers, hydrated (HNBR) SL = silicon light PU = polyurethane </td> <td style="vertical-align: top;"> E = EPDM ME = mehanite cast X = special materials </td> </tr> </table>	WB = natural rubber, soft P = acrylonitrile-butadiene rubbers (NBR) PL = acrylonitrile-butadiene rubbers (NBR) N = polychloroprene (N) Y = chlorosulfonated polyethylene (CSM)	YL = chlorosulfonated polyethylene (CSM) V = fluoroelastomer (FPM) HP = acrylonitrile-butadiene rubbers, hydrated (HNBR) SL = silicon light PU = polyurethane	E = EPDM ME = mehanite cast X = special materials									
WB = natural rubber, soft P = acrylonitrile-butadiene rubbers (NBR) PL = acrylonitrile-butadiene rubbers (NBR) N = polychloroprene (N) Y = chlorosulfonated polyethylene (CSM)	YL = chlorosulfonated polyethylene (CSM) V = fluoroelastomer (FPM) HP = acrylonitrile-butadiene rubbers, hydrated (HNBR) SL = silicon light PU = polyurethane	E = EPDM ME = mehanite cast X = special materials												
⑰	Joint sleeve materials	<table border="0"> <tr> <td style="vertical-align: top;"> P = acrylonitrile-butadiene rubbers (NBR) PL = acrylonitrile-butadiene rubbers (NBR) N = polychloroprene (N) </td> <td style="vertical-align: top;"> Y = chlorosulfonated polyethylene (CSM) V = fluoroelastomer (FPM) B = butyl rubber </td> <td style="vertical-align: top;"> X = special materials </td> </tr> </table>	P = acrylonitrile-butadiene rubbers (NBR) PL = acrylonitrile-butadiene rubbers (NBR) N = polychloroprene (N)	Y = chlorosulfonated polyethylene (CSM) V = fluoroelastomer (FPM) B = butyl rubber	X = special materials									
P = acrylonitrile-butadiene rubbers (NBR) PL = acrylonitrile-butadiene rubbers (NBR) N = polychloroprene (N)	Y = chlorosulfonated polyethylene (CSM) V = fluoroelastomer (FPM) B = butyl rubber	X = special materials												

⑱	Shaft seal materials	Stuffing box: 5846 = Ramie fiber with PTFE impregnation, asbestos-free 6426 = Aramide filament with PTFE impregnation, asbestos-free 6230 = Graphite-incorporated PTFE with slip additive, asbestos-free		
		Mechanical seal		
		Pairing of sliding material	Springs and construction materials	Secondary seals
		1st position on single seal 1st and 4th positions on double seal	2nd position	3rd position on single seal 3rd and 5th positions on double seal
	2 = CrMo cast/hard carbon 4 = Ceramic/hard carbon 5 = hard metal/hard metal, highly wear resistant 6 = silicon carbide/silicon carbide, highly wear resistant, corrosion resistant 7 = silicon carbide/silicon carbide, highly wear resistant, highly corrosion resistant X = special materials	A = 1.4300 F = 1.4571 L = Hastelloy B M = Hastelloy C4 X = special materials	P = acrylonitrile-butadiene rubbers (NBR) E = EP rubber S = silicon rubber N = polychloroprene (N) V = fluoroelastomer (FPM) TTE = EP rubber ① TTV = fluoroelastomer (FPM) ① TTS = silicon rubber① X = special materials ① double PTFE coated	

Sectional drawings and parts list for the product series AE.N ... -ZD, AEB.N ... -ZE

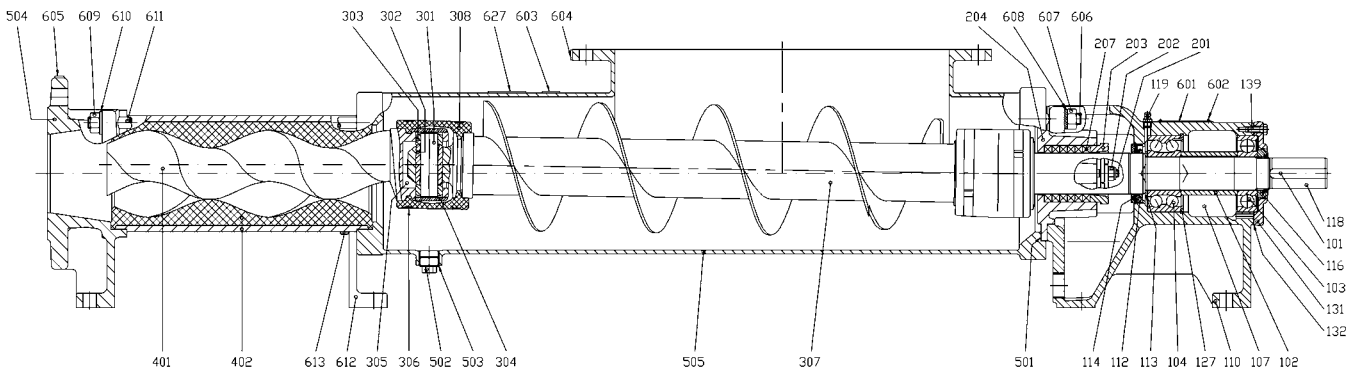

AE.N ... -ZD

Bearing 1 Hoseproof, radial bearing on drive side with sealing washer, axial bearing on the pump side with shaft sealing ring. Both bearings can be regreased. For horizontal alignment only.

Shaft seal P01: Versatile due to extra long packing length.

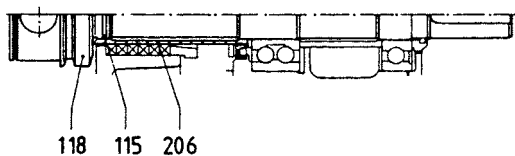

Shaft with sleeve, size 50 and larger

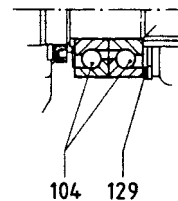

Bearing 1 size 750 and larger, axial bearing with two single-row angular-contact ball bearing

Part No.	Description	Part No.	Description	Part No.	Description
101	Feather key	123	Clamp set	209	Seal chamber ring
102	Spacing bushing	125	Plug-in shaft	212	Screw plug
103	Groove ball bearings	127	Retaining ring	213	Joint tape
104	Angular-contact ball bearing	129	Adjusting washer	214	Mechanical seal housing
107	Bearing grease	131	Bearing lid	215	Mechanical seal lid
110	Bearing bracket	132	Seal	218	O-ring
112	Rotary shaft seal	139	Hexagon screw	219	Mechanical seal
113	Spacer ring	201	Stud bolt	220	Locking pin
114	Splash ring	202	Self-locking nut	232	Rotary shaft seal
115	O-ring	203	Gland half	234	Throttle ring
116	Bearing nut	204	Stuffing box housing	235	O-ring
118	Drive shaft	206	Shaft sleeve	236	Locking pin
119	Grease nipple	207	Stuffing box packing	245	Hexagon screw
122	Lantern base	208	Flushing ring	251	Sealant

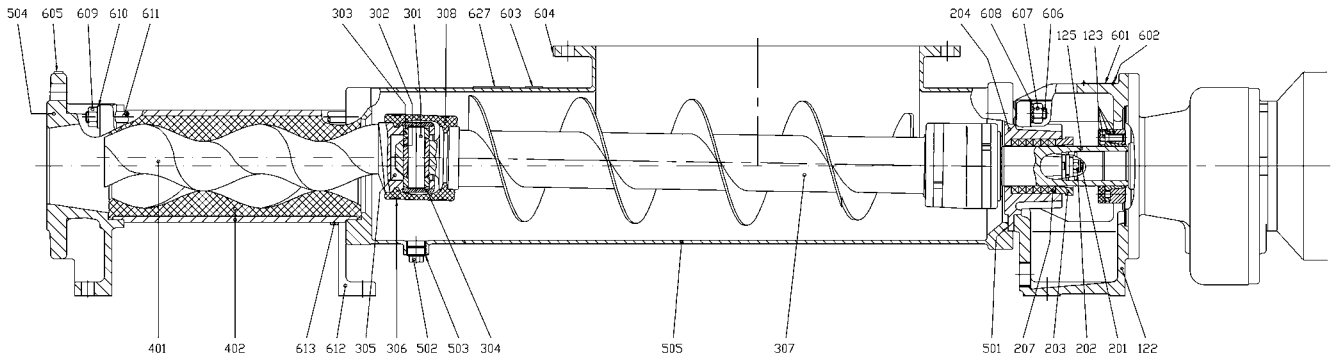

AEB.N ... -ZE

- Bearing 0 External bearing in drive unit.
Shaft seal P01: Versatile due to extra long packing length.

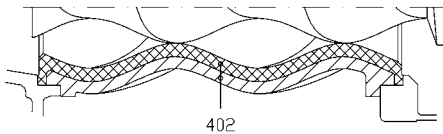

Stator with uniform elastomer wall thickness

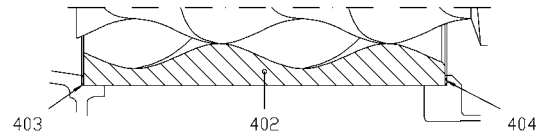

Metal stator

Part No.	Description	Part No.	Description	Part No.	Description
301	Joint pin	502	Screw plug	604	Information plate "Suction"
302 ①	Joint bush	503	Joint tape	605	Information plate "Pressure"
303	Bush for joint pin	504	Pressure housing	606	Hexagon screw
304	Joint sleeve	505	Suction housing	607	Hexagon nut
305	Joint lubricant	506	Suction housing lid	608	Serrated lock washer
306	Joint clamp	507	Seal	609	Hexagon nut
307	Joint shaft	508	Stud bolt	610	Washer
308	Joint collar	509	Hexagon nut	611	Clamp bolt
401	Rotor	510	Serrated lock washer	612	Stay
402	Stator	525	Washer	613	Hexagon screw
403	Pressure-side stator seal	601	Type plate		
404	Suction-side stator seal	602	Round head grooved pin		
501	Seal for suction housing	603	Information plate "Start-up"		

① not present on size 25 and N mechanics

Shaft seal construction

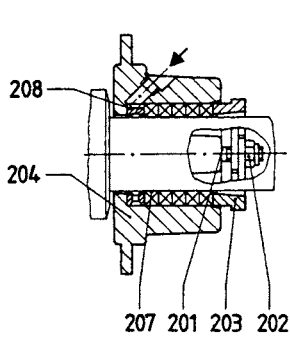

P02 Stuffing box with flushing ring
Used with highly abrasive pumped liquids with external flushing.

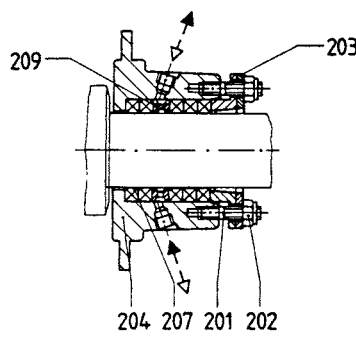

P03 Stuffing box with internal seal chamber ring
Used with pure pumped liquids with own block or with abrasive pumped liquids with external block.

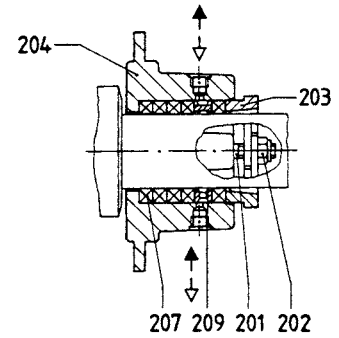

P04 Stuffing box with external seal chamber ring
Used when the external blocking fluid is incompatible with the pumped liquid or when the entrance of air must be avoided.

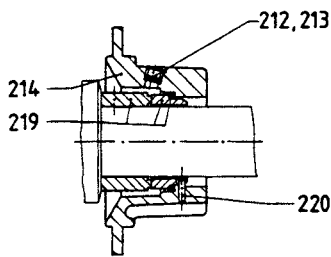

G0K/G0N Single mechanical seal, DIN 24 960, K/N version, U shape, used after discussion, $p = -0,5$ to 16 bar.

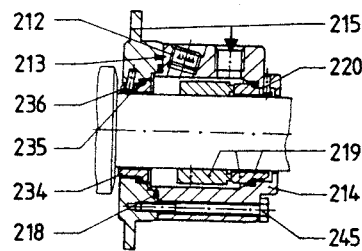

G0S/G0T Single mech. seal, DIN 24 960, K/N version, U shape, rotating part with integrated locking option, with flushing liquid connection, and pump-side throttle ring. Use after consultation.

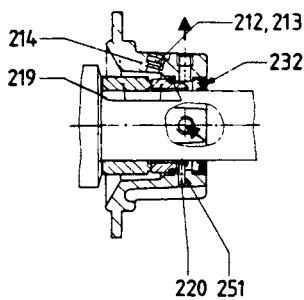

G0Q Single mech. seal, DIN 24 960, K version, U shape with quench. Use after consultation.

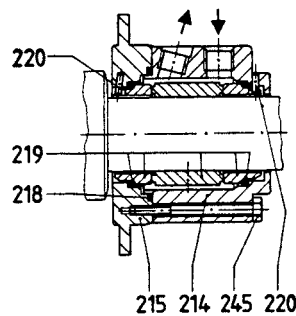

G0D Double mech. seal with barrier liquid connection. Use after consultation.

Sectional drawings and parts list for the product series AE.H ... -ZD, AEB.H ... -ZE

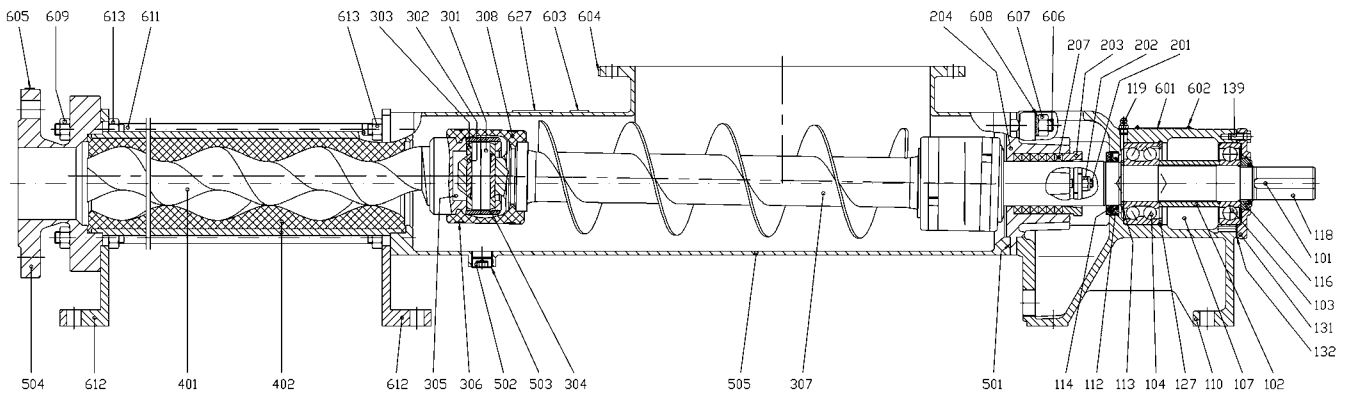

AE.H ... -ZD

Bearing 1

Hoseproof, radial bearing on drive side with sealing washer, axial bearing on the pump side with shaft sealing ring. Both bearings can be regreased. For horizontal alignment only.

Shaft seal P01:

Versatile due to extra long packing length.

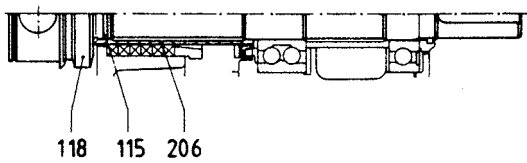

118 115 206

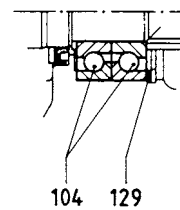

104 129

Shaft with sleeve, size 25 and larger

Bearing 1 size 380 and larger, axial bearing with two single-row angular-contact ball bearing

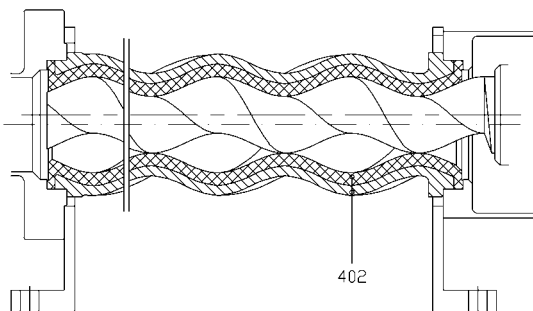

Stator with uniform elastomer wall thickness

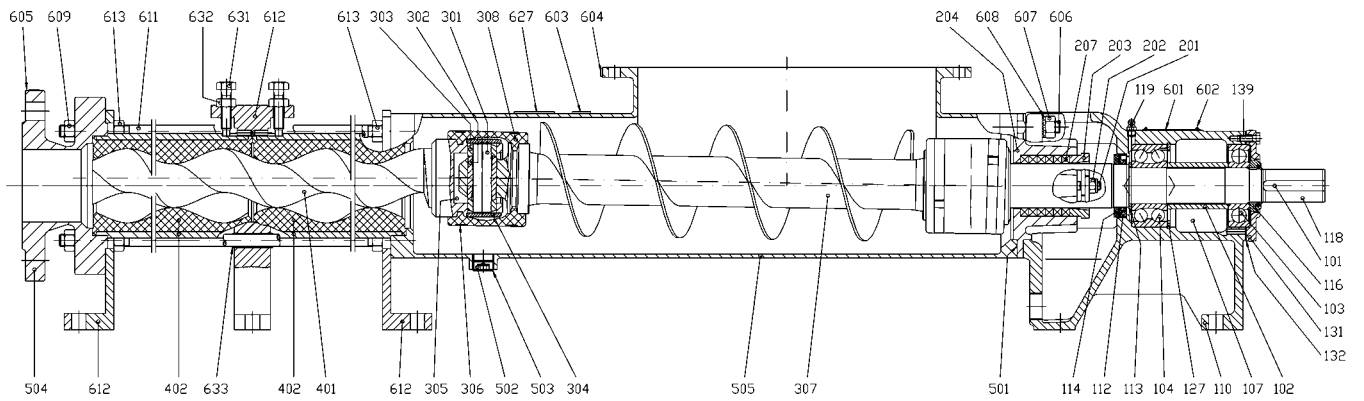

AE . + . H... - ZD

Bearing 1

Hoseproof, radial bearing on drive side with sealing washer, axial bearing on the pump side with shaft sealing ring. Both bearings can be regreased. For horizontal alignment only.

Shaft seal P01:

Versatile due to extra long packing length.

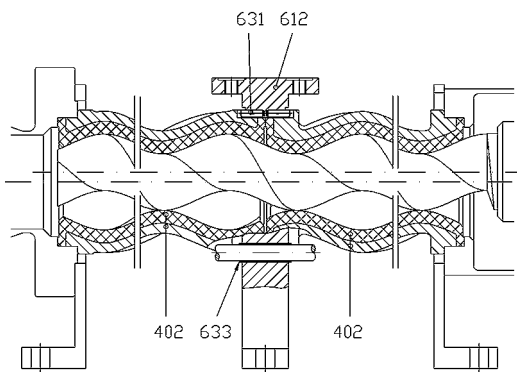

Stator with uniform elastomer wall thickness

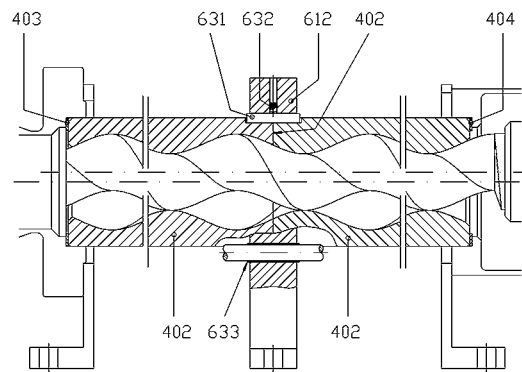

Metal stator

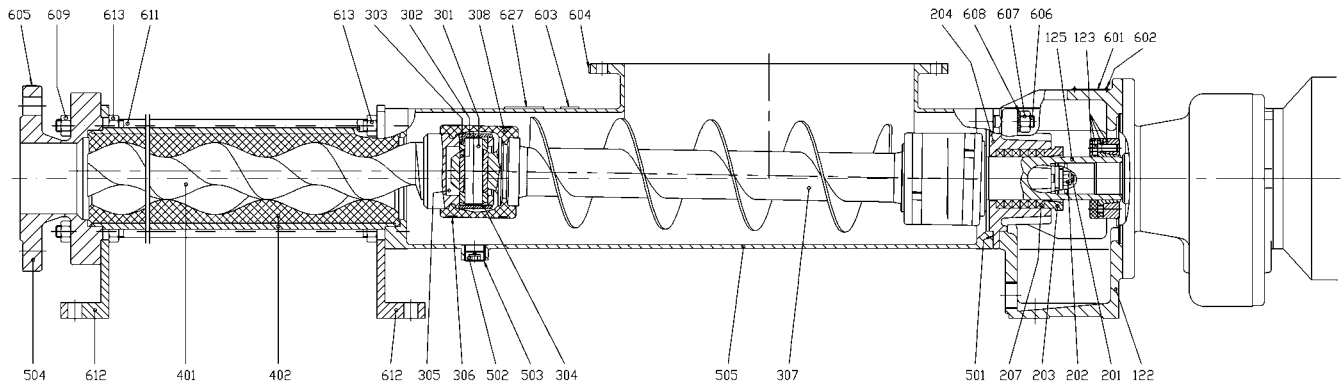

AEB.H ...-ZE

- Bearing **0**: External bearing in drive unit.
 Shaft seal **P01**: Versatile due to extra long packing length.

Part No.	Description	Part No.	Description	Part No.	Description
101	Feather key	208	Flushing ring	501	Seal for suction housing
102	Distance piece	209	Seal chamber ring	502	Screw plug
103	Groove ball bearings	212	Screw plug	503	Joint tape
104	Angular-contact ball bearing	213	Joint tape	504	Pressure housing
107	Bearing grease	214	Mechanical seal housing	505	Suction housing
110	Bearing bracket	215	Mechanical seal lid	506	Suction housing lid
112	Rotary shaft seal	218	O-ring	507	Seal
113	Spacer ring	219	Mechanical seal	508	Stud bolt
114	Splash ring	220	Locking pin	509	Hexagon nut
115	O-ring	232	Rotary shaft seal	510	Serrated lock washer
116	Bearing nut	234	Throttle ring	512	Reducing flange
118	Drive shaft	235	O-ring	513	O-ring
119	Grease nipple	236	Locking pin	525	Washer
122	Lantern base	245	Hexagon screw	601	Type plate
123	Clamp set	251	Sealant	602	Round head grooved pin
125	Plug-in shaft	301	Joint pin	603	Information plate "Start-up"
127	Retaining ring	302	Joint bush	604	Information plate "Suction"
129	Adjusting washer	303	Bush for joint pin	605	Information plate "Pressure"
131	Bearing lid	304	Joint sleeve	606	Hexagon screw
132	Seal	305	Joint lubricant	607	Hexagon nut
139	Hexagon screw	306	Joint clamp	608	Serrated lock washer
201	Stud bolt	307	Joint shaft	609	Hexagon nut
202	Self-locking nut	308	Joint collar	611	Clamp bolt
203	Gland half	401	Rotor	612	Stay
204	Stuffing box housing	402	Stator	613	Hexagon screw
206	Shaft sleeve	403	Pressure-side stator seal	631	Fastening piece
207	Stuffing box packing	404	Suction-side stator seal	632	Hexagon nut
				633	Spacer

Pump dimensions, auxiliary connections, possible branch positions, weights

AEB 1N 25 ... 1450-ZE

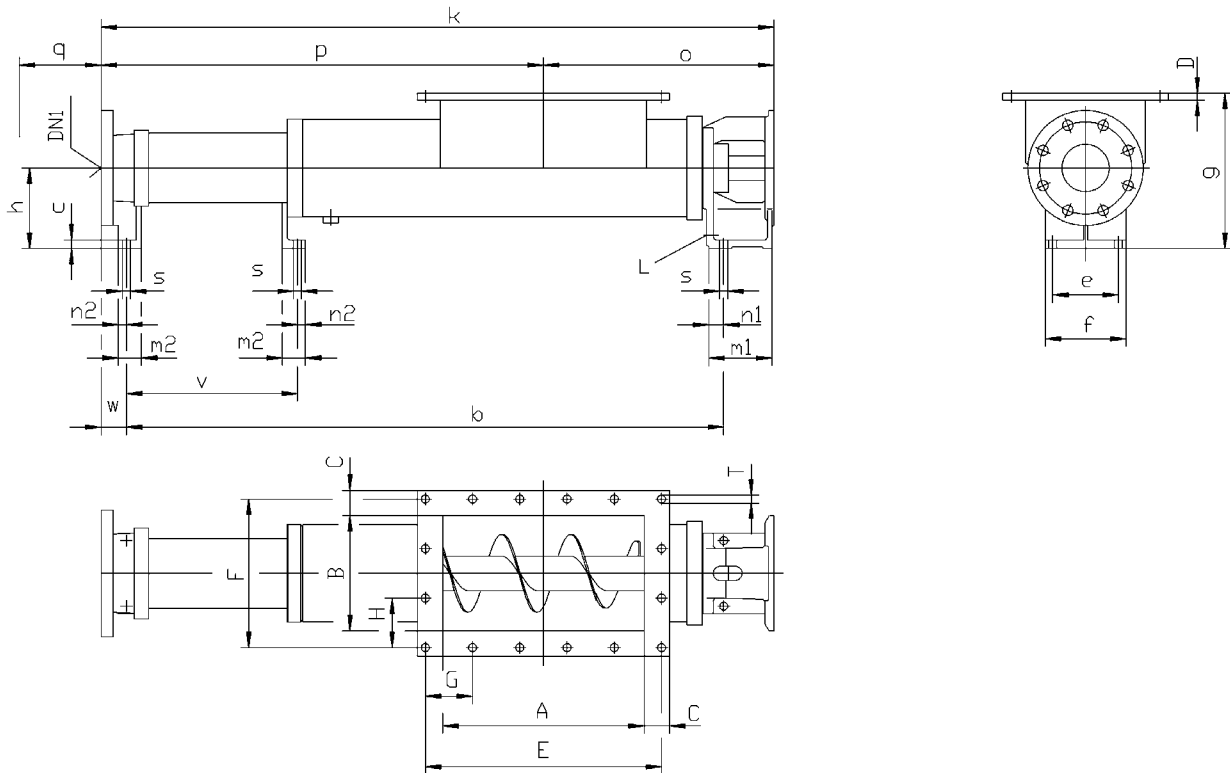

Dimensions in mm, standard widths of the ANSI flanges (DN) in inches.
Subject to change.

Type	Pump dimensions															
	b	c	e	f	g	h	m1	m2	n1	n2	o	q ②	s	v	L	M ①
AEB 1N 25-ZE	553	10	75	95	180	90	84	30	19	11	240	335	9	-	Rp%	
AEB 1N 50-ZE	657	10	85	105	200	100	93	30	19	11	272	400	9	-	Rp%	
AEB 1N 100-ZE	818	13	100	125	240	125	106	38	25	13	333	500	11,5	-	Rp½	
AEB 1N 200-ZE	1037	15	114	140	270	140	110	40	26	14	400,5	660	14	-	Rp¾	
AEB 1N 380-ZE	1198,5	16	132	168	310	160	128	50	31	19	447	760	18	-	Rp¾	
AEB 1N 750-ZE	1498,5	16	164	200	350	180	131	50	31	19	528	960	18	458	Rp¾	
AEB 1N 1450-ZE	1905	21	200	245	420	225	153	63	40	23	678	1230	22	586	Rp1	

Type	Connection dimensions of pressure joint												Connection dimensions of inlet hopper								
	Flanges DIN 2501 PN 16 ⑤				Flanges ANSI B16.1 class 125 ③				Flanges ANSI B16.5 class 150 ③				A	B	C	D	E	F	G	H	T
	DN1	k	p	w	DN1	k	p	w	DN1	k	p	w									
AEB 1N 25-ZE	40	662	422	41	1½"	659	419	38	1½"	662	422	41	200	125	33	10	246	170	82	85	11,5
AEB 1N 50-ZE	50	777	505	43	2"	773	501	39	2"	777	505	43	244	145	33	10	288	189	72	63	11,5
AEB 1N 100-ZE	65	942	609	40	2½"	941	608	39	2½"	946	613	44	290	170	34	10	335	216	67	72	11,5
AEB 1N 200-ZE	80	1168,5	768	44	3"	1166,5	766	42	3"	1171,5	771	47	350	200	44	12	410	258	82	86	14
AEB 1N 380-ZE	100	1341	894	41	4"	1343	896	43	4"	1343	896	43	410	260	45	12	470	320	94	80	14
AEB 1N 750-ZE	125	1646	1118	44	5"	1646	1118	44	5"	1646	1118	44	522	300	45	12	581	360	83	90	14
AEB 1N 1450-ZE	150	2075	1397	53	6"	2075	1397	53	6"	2075	1397	53	630	370	55	12	688	430	86	86	14

① Maximum mass: kg

② Stator dismantling dimensions

③ Sealing surface: stock finish

⑤ up to DN 100 sealing surface DIN 2526, shape C, processed like shape A; starting from DN 125 sealing surface DIN 2526, shape A

AEB 2N 25 ... 1450-ZE

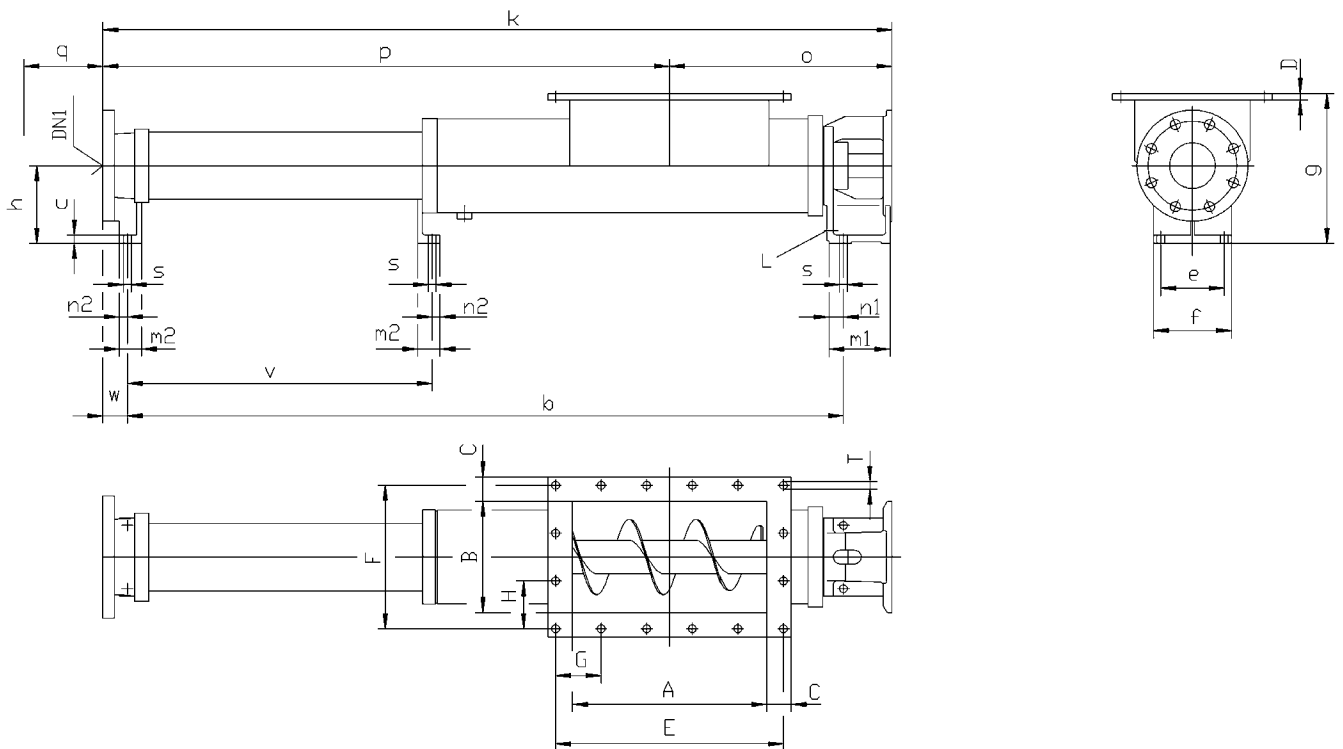

Dimensions in mm, standard widths of the ANSI flanges (DN) in inches.
Subject to change.

Type	Pump dimensions															
	b	c	e	f	g	h	m1	m2	n1	n2	o	q ②	s	v	L	M ①
AEB 2N 25-ZE	679	10	75	95	180	90	84	30	19	11	240	335	9	-	Rp%	
AEB 2N 50-ZE	817	10	85	105	200	100	93	30	19	11	272	400	9	-	Rp%	
AEB 2N 100-ZE	1018	13	100	125	240	125	106	38	25	13	333	500	11,5	-	Rp½	
AEB 2N 200-ZE	1289	15	114	140	270	140	110	40	26	14	400,5	660	14	-	Rp¾	
AEB 2N 380-ZE	1504,5	16	132	168	310	160	128	50	31	19	447	760	18	-	Rp¾	
AEB 2N 750-ZE	1898,5	16	164	200	350	180	131	50	31	19	528	960	18	858	Rp¾	
AEB 2N 1450-ZE	2410	21	200	245	420	225	153	63	40	23	678	1230	22	1091	Rp1	

Type	Connection dimensions of pressure joint												Connection dimensions of inlet hopper								
	Flanges DIN 2501 PN 16 ⑤				Flanges ANSI B16.1 class 125 ③				Flanges ANSI B16.5 class 150 ③				A	B	C	D	E	F	G	H	T
	DN1	k	p	w	DN1	k	p	w	DN1	k	p	w									
AEB 2N 25-ZE	40	788	548	41	1½"	785	545	38	1½"	788	548	41	200	125	33	10	246	170	82	85	11,5
AEB 2N 50-ZE	50	937	665	43	2"	933	661	39	2"	937	665	43	244	145	33	10	288	189	72	63	11,5
AEB 2N 100-ZE	65	1142	809	40	2½"	1141	808	39	2½"	1146	813	44	290	170	34	10	335	216	67	72	11,5
AEB 2N 200-ZE	80	1420,5	1020	44	3"	1418,5	1018	42	3"	1423,5	1023	47	350	200	44	12	410	258	82	86	14
AEB 2N 380-ZE	100	1647	1200	41	4"	1649	1202	43	4"	1649	1202	43	410	260	45	12	470	320	94	80	14
AEB 2N 750-ZE	125	2046	1518	44	5"	2046	1518	44	5"	2046	1518	44	522	300	45	12	581	360	83	90	14
AEB 2N 1450-ZE	150	2580	1902	53	6"	2580	1902	53	6"	2580	1902	53	630	370	55	12	688	430	86	86	14

① Maximum mass: kg

② Stator dismantling dimensions

③ Sealing surface: stock finish

⑤ up to DN 100 sealing surface DIN 2526, shape C, processed like shape A; starting from DN 125 sealing surface DIN 2526, shape A

AE 1N 25 ... 5000-ZD

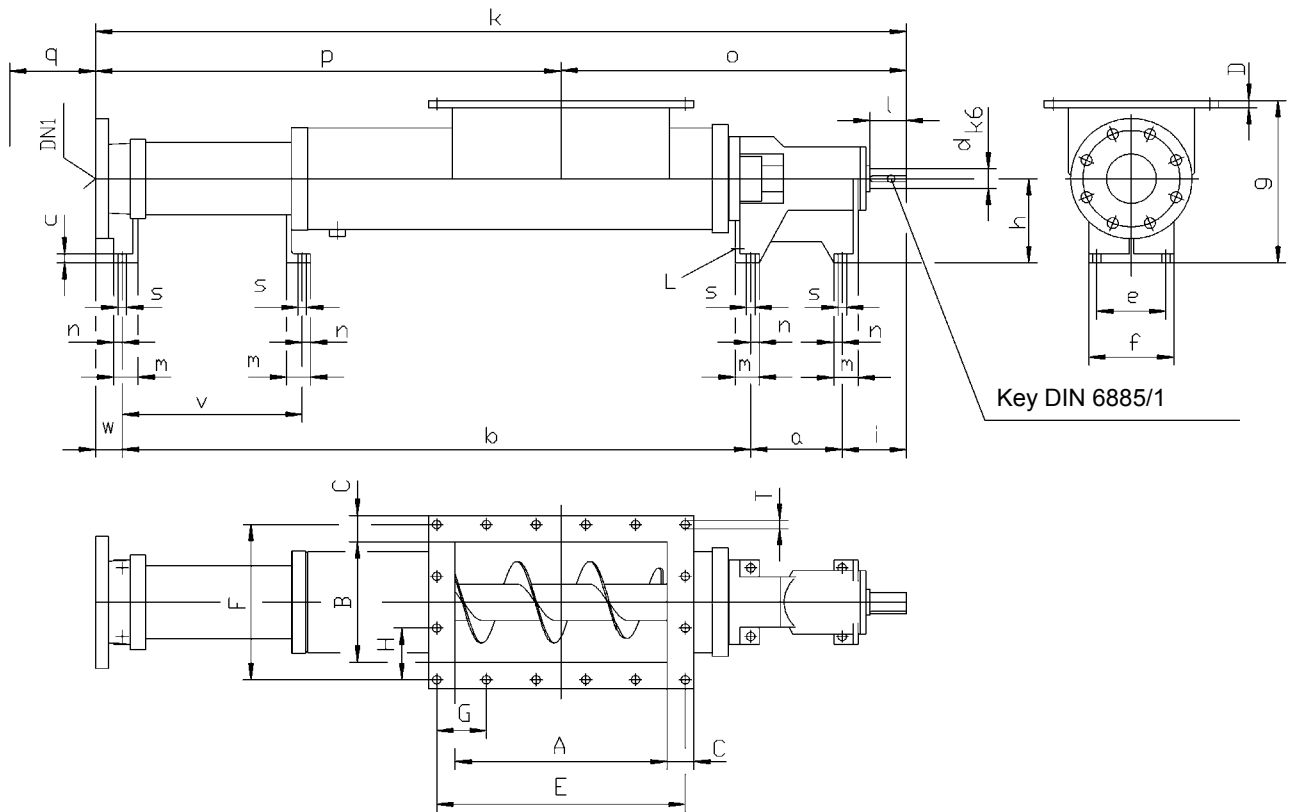

Dimensions in mm, standard widths of the ANSI flanges (DN) in inches.
Subject to change.

Type	Pump dimensions																	
	a	b	c	d	e	f	g	h	i	l	m	n	o	q ②	s	v	L	M ①
AE 1N 25-ZD	114	553	10	18	75	95	180	90	65	30	30	11	351	335	9	-	Rp $\frac{3}{8}$	
AE 1N 50-ZD	122	657	10	22	85	105	200	100	79	40	30	11	396	400	9	-	Rp $\frac{3}{8}$	
AE 1N 100-ZD	140	818	13	28	100	125	240	125	95	50	38	13	484	500	11,5	-	Rp $\frac{1}{2}$	
AE 1N 200-ZD	151	1037	15	32	114	140	270	140	106	60	40	14	570	660	14	-	Rp $\frac{3}{4}$	
AE 1N 380-ZD	171	1198,5	16	42	132	168	310	160	118	65	50	19	634,5	760	18	-	Rp $\frac{3}{4}$	
AE 1N 750-ZD	190	1498,5	16	48	164	200	350	180	129,5	75	50	19	744	960	18	458	Rp $\frac{3}{4}$	
AE 1N 1450-ZD	220	1905	21	60	200	245	420	225	158	90	63	23	939	1230	22	586	Rp1	
AE 1N 2700-ZD	266	2298	24	75	245	290	500	250	182	110	65	23	1105	1490	22	703	Rp1	
AE 1N 5000-ZD	320	2770	29	95	290	350	600	280	215	130	80	30	1333	1770	27	764	Rp1	

Type	Connection dimensions of pressure joint												Connection dimensions of inlet hopper								
	Flanges DIN 2501 PN 16 ⑤				Flanges ANSI B16.1 class 125 ③				Flanges ANSI B16.5 class 150 ③				A	B	C	D	E	F	G	H	T
	DN1	k	p	w	DN1	k	p	w	DN1	k	p	w									
AE 1N 25-ZD	40	773	422	41	1½"	770	419	38	1½"	773	422	41	200	125	33	10	246	170	82	85	11,5
AE 1N 50-ZD	50	901	505	43	2"	897	501	39	2"	901	505	43	244	145	33	10	288	189	72	63	11,5
AE 1N 100-ZD	65	1093	609	40	2½"	1092	608	39	2½"	1097	613	44	290	170	34	10	335	216	67	72	11,5
AE 1N 200-ZD	80	1338	768	44	3"	1336	766	42	3"	1341	771	47	350	200	44	12	410	258	82	86	14
AE 1N 380-ZD	100	1528,5	894	41	4"	1530,5	896	43	4"	1530,5	896	43	410	260	45	12	470	320	94	80	14
AE 1N 750-ZD	125	1862	1118	44	5"	1862	1118	44	5"	1862	1118	44	522	300	45	12	581	360	83	90	14
AE 1N 1450-ZD	150	2336	1397	53	6"	2336	1397	53	6"	2336	1397	53	630	370	55	12	688	430	86	86	14
AE 1N 2700-ZD	200	2808	1703	62	8"	2808	1703	62	8"	2808	1703	62	850	400	55	12	920	470	92	94	14
AE 1N 5000-ZD	250	3380	2047	75	10"	3380	2047	75	10"	3380	2047	75	1000	500	55	12	1068	570	89	95	14

① Maximum mass: kg

② Stator dismantling dimensions

③ Sealing surface: stock finish

⑤ up to DN 100 sealing surface DIN 2526, shape C, processed like shape A; starting from DN 125 sealing surface DIN 2526, shape A

AE 2N 25 ... 5000-ZD

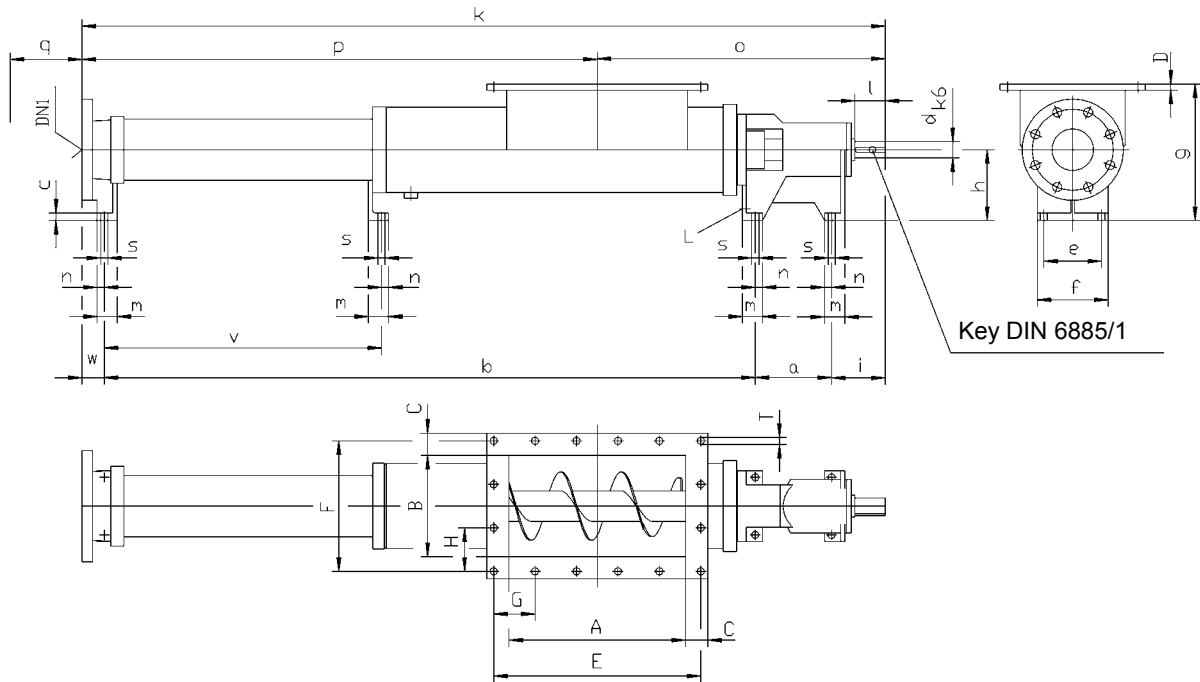

Dimensions in mm, standard widths of the ANSI flanges (DN) in inches.
Subject to change.

Type	Pump dimensions																	
	a	b	c	d	e	f	g	h	i	l	m	n	o	q ②	s	v	L	M ①
AE 2N 25-ZD	114	679	10	18	75	95	180	90	65	30	30	11	351	335	9	-	Rp $\frac{3}{8}$	
AE 2N 50-ZD	122	817	10	22	85	105	200	100	79	40	30	11	396	400	9	-	Rp $\frac{3}{8}$	
AE 2N 100-ZD	140	1018	13	28	100	125	240	125	95	50	38	13	484	500	11,5	-	Rp $\frac{1}{2}$	
AE 2N 200-ZD	151	1289	15	32	114	140	270	140	106	60	40	14	570	660	14	-	Rp $\frac{3}{4}$	
AE 2N 380-ZD	171	1504,5	16	42	132	168	310	160	118	65	50	19	634,5	760	18	-	Rp $\frac{3}{4}$	
AE 2N 750-ZD	190	1898,5	16	48	164	200	350	180	129,5	75	50	19	744	960	18	858	Rp $\frac{3}{4}$	
AE 2N 1450-ZD	220	2410	21	60	200	245	420	225	158	90	63	23	939	1230	22	1091	Rp1	
AE 2N 2700-ZD	266	2956	24	75	245	290	500	250	182	110	65	23	1105	1490	22	1361	Rp1	
AE 2N 5000-ZD	320	3575	29	95	290	350	600	280	215	130	80	30	1333	1770	27	1569	Rp1	

Type	Connection dimensions of pressure joint																							
	Flanges DIN 2501 PN 16 ⑤				Flanges ANSI B16.1 class 125 ③				Flanges ANSI B16.5 class 150 ③				Flanges DIN 2501 PN 25 ⑥				Flanges ANSI B16.1 class 250 ③				Flanges ANSI B16.5 class 300 ③			
	DN1	k	p	w	DN1	k	p	w	DN1	k	p	w	DN1	k	p	w	DN1	k	p	w	DN1	k	p	w
AE 2N 25-ZD	40	899	548	41	1½"	896	545	38	1½"	899	548	41												
AE 2N 50-ZD	50	1061	665	43	2"	1057	661	39	2"	1061	665	43												
AE 2N 100-ZD	65	1293	809	40	2½"	1296	808	39	2½"	1297	813	44	65	1298	814	45	2½"	1300	816	47	2½"	1300	816	47
AE 2N 200-ZD	80	1590	1020	44	3"	1588	1018	42	3"	1593	1023	47	80	1595	1025	49	3"	1598	1028	52	3"	1598	1028	52
AE 2N 380-ZD	100	1834,5	1200	41	4"	1836,5	1202	43	4"	1836,5	1202	43	100	1840,5	1206	47	4"	1844,5	1210	51	4"	1844,5	1210	51
AE 2N 750-ZD	125	2262	1518	44	5"	2262	1518	44	5"	2262	1518	44	125	2268	1524	50	5"	2273	1529	55	5"	2273	1529	55
AE 2N 1450-ZD	150	2841	1902	53	6"	2841	1902	53	6"	2841	1902	53	150	2849	1910	61	6"	2852	1913	64	6"	2852	1913	64
AE 2N 2700-ZD	200	3466	2361	62	8"	3466	2361	62	8"	3466	2361	62												
AE 2N 5000-ZD	250	4185	2852	75	10"	4185	2852	75	10"	4185	2852	75												

Type	Connection dimensions of inlet hopper									
	A	B	C	D	E	F	G	H	T	
AE 2N 25-ZD	200	125	33	10	246	170	82	85	11,5	
AE 2N 50-ZD	244	145	33	10	288	189	72	63	11,5	
AE 2N 100-ZD	290	170	34	10	335	216	67	72	11,5	
AE 2N 200-ZD	350	200	44	12	410	258	82	86	14	
AE 2N 380-ZD	410	260	45	12	470	320	94	80	14	
AE 2N 750-ZD	522	300	45	12	581	360	83	90	14	
AE 2N 1450-ZD	630	370	55	12	688	430	86	86	14	
AE 2N 2700-ZD	850	400	55	12	920	470	92	94	14	
AE 2N 5000-ZD	1000	500	55	12	1068	570	89	95	14	

① Maximum mass: kg ② Stator dismantling dimensions ③ Sealing surface: stock finish

⑤ up to DN 100 sealing surface DIN 2526, shape C, processed like shape A; starting from DN 125 sealing surface DIN 2526, shape A

⑥ Sealing surface DIN 2526, shape C, processed like shape A

AEB 4H 25 ... 50-ZE

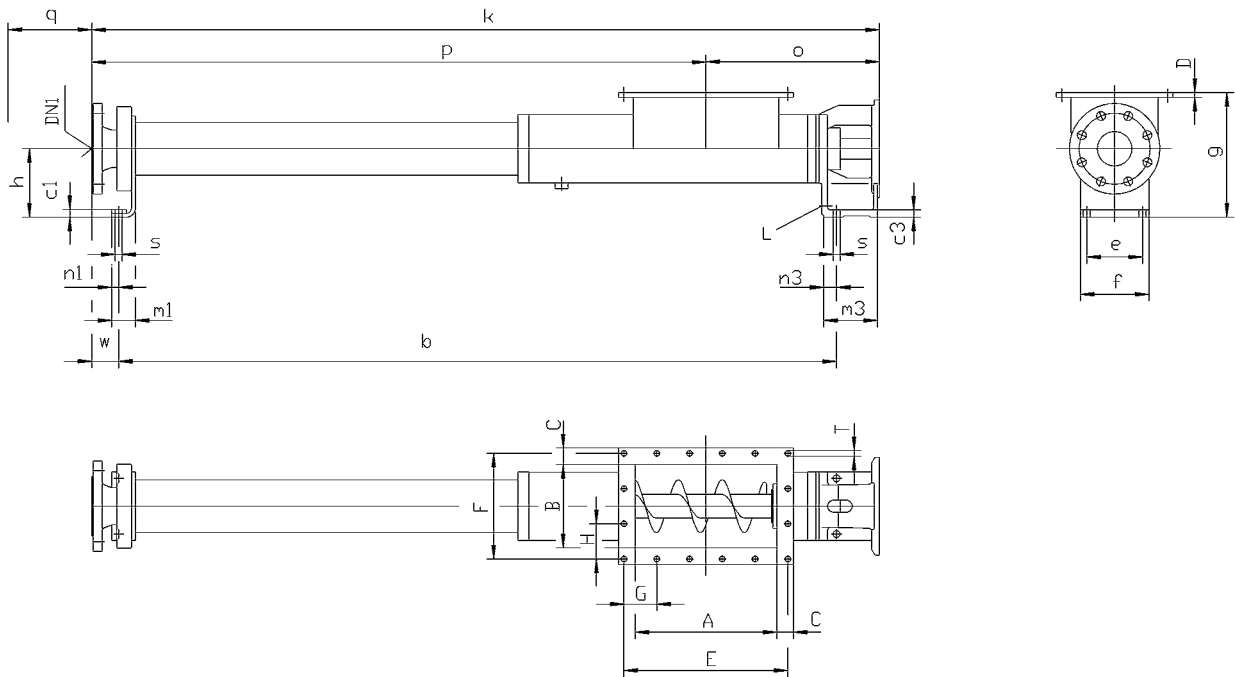

Dimensions in mm, standard widths of the ANSI flanges (DN) in inches.
Subject to change.

Type	Pump dimensions															
	b	c1	c3	e	f	g	h	m1	m3	n1	n3	o	q ②	s	L	M ①
AEB 4H 25-ZE	956	8	10	85	105	190	100	42	93	11	19	256	465	9	Rp $\frac{3}{8}$	
AEB 4H 50-ZE	1186	13	13	100	125	225	125	48	106	13	25	302	605	11,5	Rp $\frac{1}{2}$	

Type	Connection dimensions of pressure joint								Connection dimensions of inlet hopper								
	Flanges DIN 2501 PN 40 ⑥				Flanges ANSI B16.5 class 300 ③				A	B	C	D	E	F	G	H	T
	DN1	k	p	w	DN1	k	p	w									
AEB 4H 25-ZE	40	1080	824	47	1½"	1102	846	69	200	125	33	10	246	170	82	85	11,5
AEB 4H 50-ZE	50	1318	1016	48	2"	1339,5	1037,5	69,5	244	145	33	10	288	189	72	63	11,5

① Maximum mass: kg

② Stator dismantling dimensions

③ Sealing surface: stock finish

⑥ Sealing surface DIN 2526, shape C

AE 1+1H 25 ... 2700-ZD

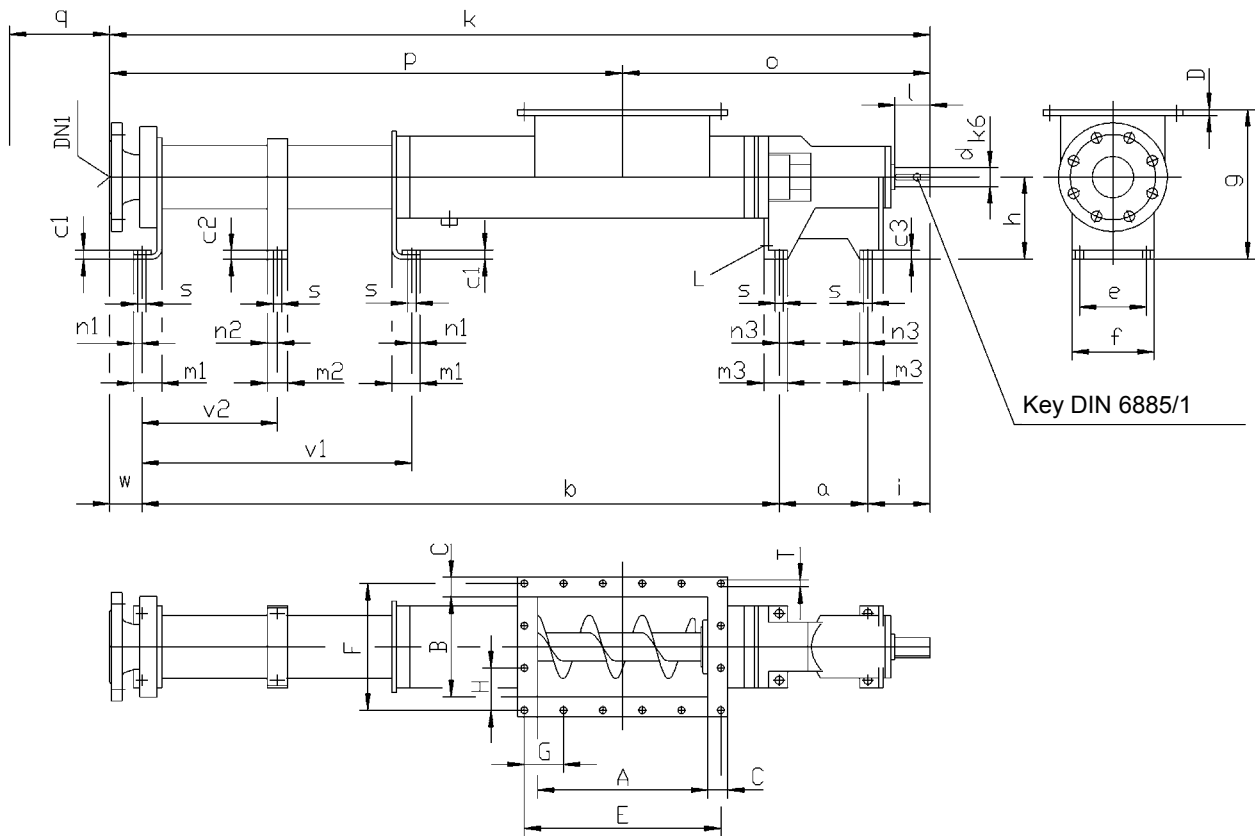

Dimensions in mm, standard widths of the ANSI flanges (DN) in inches.
Subject to change.

Type	Pump dimensions																								
	a	b	c1	c2	c3	d	e	f	g	h	i	l	m1	m2	m3	n1	n2	n3	o	q ②	s	v1	v2	L	M ①
AE1+1H 25-ZD	122	715	8	-	10	22	85	105	190	100	79	40	42	-	30	11	-	11	380	465	9	-	-	Rp¾	
AE1+1H 50-ZD	140	879	13	-	13	28	100	125	225	125	95	50	48	-	38	13	-	13	453	605	11,5	-	-	Rp½	
AE1+1H 100-ZD	151	1086	16	15	15	32	114	140	255	140	106	60	48	35	40	14	17,5	14	524	560	14	-	231	Rp¾	
AE1+1H 200-ZD	171	1354,5	16	16	16	42	132	168	290	160	118	65	50	40	50	19	20	19	618,5	710	18	-	283	Rp¾	
AE1+1H 380-ZD	190	1591,5	16	16	16	48	164	200	330	180	129,5	75	50	45	50	19	22,5	19	690	830	18	674	338,5	Rp¾	
AE1+1H 750-ZD	220	2038	20	21	21	60	200	245	395	225	158	90	70	45	63	23	22,5	23	851	1040	22	899	450,5	Rp1	
AE1+1H 1450-ZD	266	2532	20	24	24	75	245	290	445	250	182	110	70	50	65	23	25	23	1036	1310	22	1118	560	Rp1	
AE1+1H 2700-ZD	320	3083	28	29	29	95	290	350	530	280	215	130	80	55	80	30	27,5	30	1233	1610	27	1352	677	Rp1	

Type	Connection dimensions of pressure joint								Connection dimensions of inlet hopper								
	Flanges DIN 2501 PN 40 ⑥				Flanges ANSI B16.5 class 300 ③				A	B	C	D	E	F	G	H	T
	DN1	k	p	w	DN1	k	p	w									
AE1+1H 25-ZD	40	963	583	47	1½"	985	605	69	200	125	33	10	246	170	82	85	11,5
AE1+1H 50-ZD	50	1162	709	48	2"	1183,5	730,5	69,5	244	145	33	10	288	189	72	63	11,5
AE1+1H 100-ZD	65	1398	874	55	2½"	1422,2	898,2	79,2	290	170	34	10	335	216	67	72	11,5
AE1+1H 200-ZD	80	1705,5	1087	62	3"	1725,5	1107	82	350	200	44	12	410	258	82	86	14
AE1+1H 380-ZD	100	1985	1295	74	4"	2004	1314	93	410	260	45	12	470	320	94	80	14
AE1+1H 750-ZD	125	2489	1638	73	5"	2519,5	1668,5	103,5	522	300	45	12	581	360	83	90	14
AE1+1H 1450-ZD	150	3057	2021	77	6"	3079	2043	99	630	370	55	12	688	430	86	86	14
AE1+1H 2700-ZD	200	3712	2479	94	8"	3735	2502	117	850	400	55	12	920	470	92	94	14

① Maximum mass: kg

② Stator dismantling dimensions

③ Sealing surface: stock finish

⑥ Sealing surface DIN 2526, shape C

AE2H 100 ... 1450-ZD

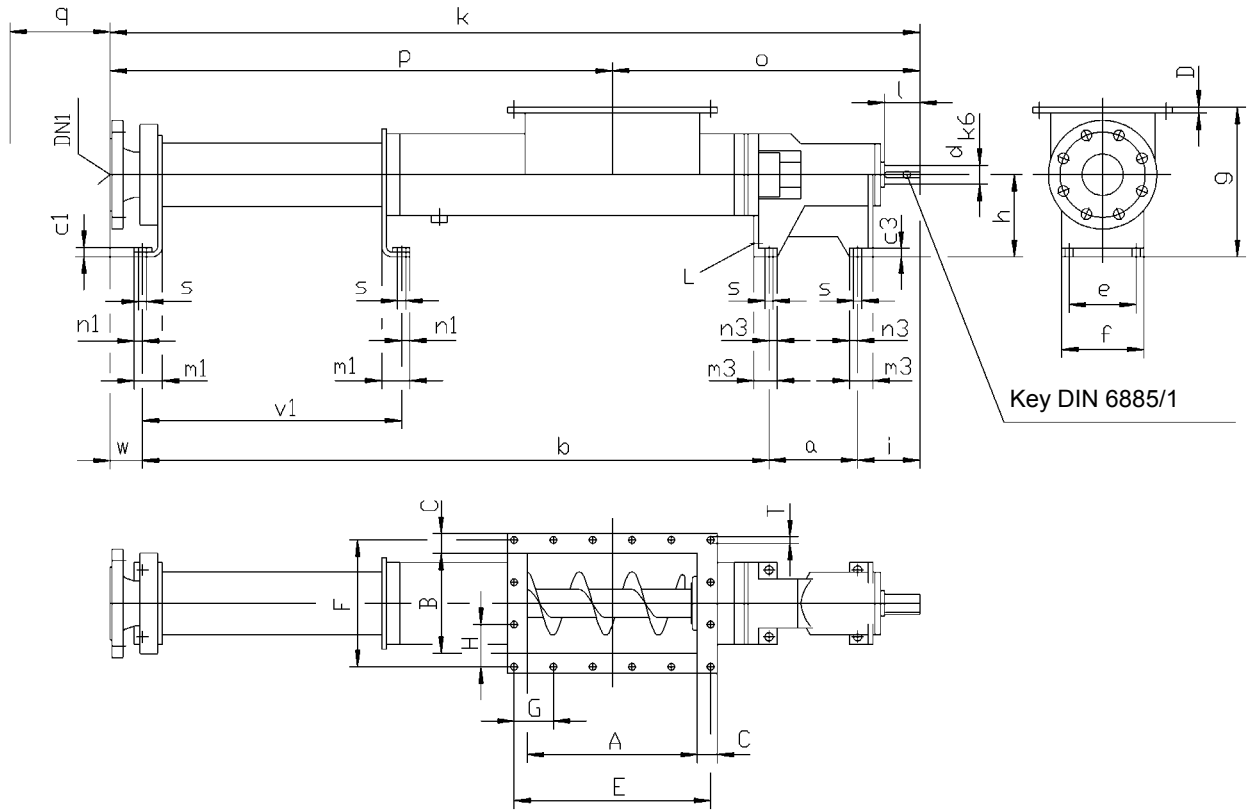

Dimensions in mm, standard widths of the ANSI flanges (DN) in inches.
Subject to change.

Type	Pump dimensions																				
	a	b	c1	c3	d	e	f	g	h	i	l	m1	m3	n1	n3	o	q ^②	s	v1	L	M ^①
AE 2H 100-ZD	151	1068	16	15	32	114	140	255	140	106	60	48	40	14	14	524	560	14	-	Rp¾	
AE 2H 200-ZD	171	1332,5	16	16	42	132	168	290	160	118	65	50	50	19	19	618,5	710	18	-	Rp¾	
AE 2H 380-ZD	190	1565,5	16	16	48	164	200	330	180	129,5	75	50	50	19	19	690	830	18	648	Rp¾	
AE 2H 750-ZD	220	2008	20	21	60	200	245	395	225	158	90	70	63	23	23	851	1040	22	869	Rp1	
AE 2H 1450-ZD	266	2496	20	24	75	245	290	445	250	182	110	70	65	23	23	1036	1310	22	1082	Rp1	

Type	Connection dimensions of pressure joint								Connection dimensions of inlet hopper									
	Flanges DIN 2501 PN 40 ^⑥				Flanges ANSI B16.5 class 300 ^③				A	B	C	D	E	F	G	H	T	
	DN1	k	p	w	DN1	k	p	w										
AE 2H 100-ZD	65	1380	856	55	2½"	1404,2	880,2	79,2	290	170	34	10	335	216	67	72	11,5	
AE 2H 200-ZD	80	1683,5	1065	62	3"	1703,5	1085	82	350	200	44	12	410	258	82	86	14	
AE 2H 380-ZD	100	1959	1269	74	4"	1978	1288	93	410	260	45	12	470	320	94	80	14	
AE 2H 750-ZD	125	2459	1608	73	5"	2489,5	1638,5	103,5	522	300	45	12	581	360	83	90	14	
AE 2H 1450-ZD	150	3021	1985	77	6"	3043	2007	99	630	370	55	12	688	430	86	86	14	

① Maximum mass: kg

② Stator dismantling dimensions

③ Sealing surface: stock finish

⑥ Sealing surface DIN 2526, shape C

AE 2+2H 100 ... 2700-ZD

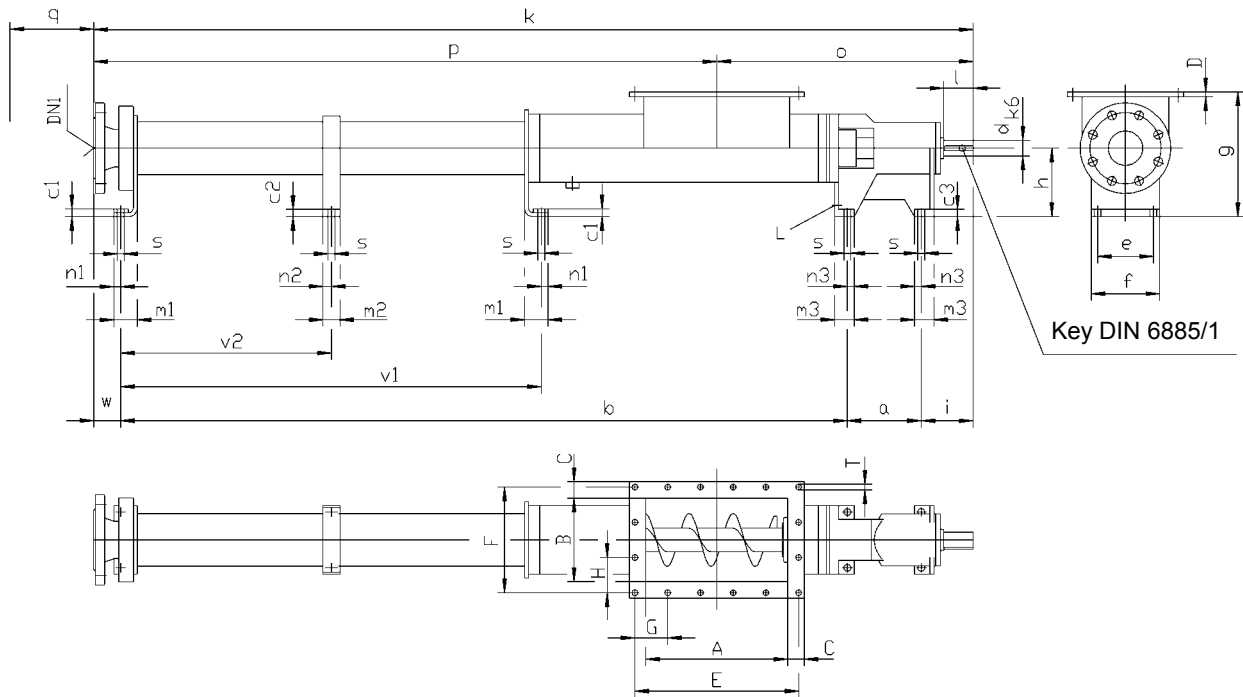

Dimensions in mm, standard widths of the ANSI flanges (DN) in inches.
Subject to change.

Type	Pump dimensions																								
	a	b	c1	c2	c3	d	e	f	g	h	i	l	m1	m2	m3	n1	n2	n3	o	q ②	s	v1	v2	L	M ①
AE 2+2H 100-ZD	151	1468	16	15	15	32	114	140	255	140	106	60	48	35	40	14	17,5	14	524	560	14	-	431	Rp½	
AE 2+2H 200-ZD	171	1858,5	16	16	16	42	132	168	290	160	118	65	50	40	50	19	20	19	618,5	710	18	-	535	Rp½	
AE 2+2H 380-ZD	190	2203,5	16	16	16	48	164	200	330	180	129,5	75	50	45	50	19	22,5	19	690	830	18	1286	644,5	Rp¾	
AE 2+2H 750-ZD	220	2838	20	21	21	60	200	245	395	225	158	90	70	45	63	23	22,5	23	851	1040	22	1699	850,5	Rp1	
AE 2+2H 1450-ZD	266	3542	20	24	24	75	245	290	445	250	182	110	70	50	65	23	25	23	1036	1310	22	2128	1065	Rp1	
AE 2+2H 2700-ZD	320	4399	28	29	29	95	290	350	530	280	215	130	80	55	80	30	27,5	30	1233	1610	27	2668	1335	Rp1	

Type	Connection dimensions of pressure joint								Connection dimensions of inlet hopper								
	Flanges DIN 2501 PN 40 ⑥				Flanges ANSI B16.5 class 300 ③				A	B	C	D	E	F	G	H	T
	DN1	k	p	w	DN1	k	p	w									
AE 2+2H 100-ZD	65	1798	1274	55	2½"	1822,2	1298,2	79,2	290	170	34	10	335	216	67	72	11,5
AE 2+2H 200-ZD	80	2209,5	1591	62	3"	2229,5	1611	82	350	200	44	12	410	258	82	86	14
AE 2+2H 380-ZD	100	2597	1907	74	4"	2616	1926	93	410	260	45	12	470	320	94	80	14
AE 2+2H 750-ZD	125	3289	2438	73	5"	3319,5	2468,5	103,5	522	300	45	12	581	360	83	90	14
AE 2+2H 1450-ZD	150	4067	3031	77	6"	4089	3053	99	630	370	55	12	688	430	86	86	14
AE 2+2H 2700-ZD	200	5028	3795	94	8"	5051	3818	117	850	400	55	12	920	470	92	94	14

① Maximum mass: kg

② Stator dismantling dimensions

③ Sealing surface: stock finish

⑥ Sealing surface DIN 2526, shape C

AE 4H 25 ... 1450-ZD

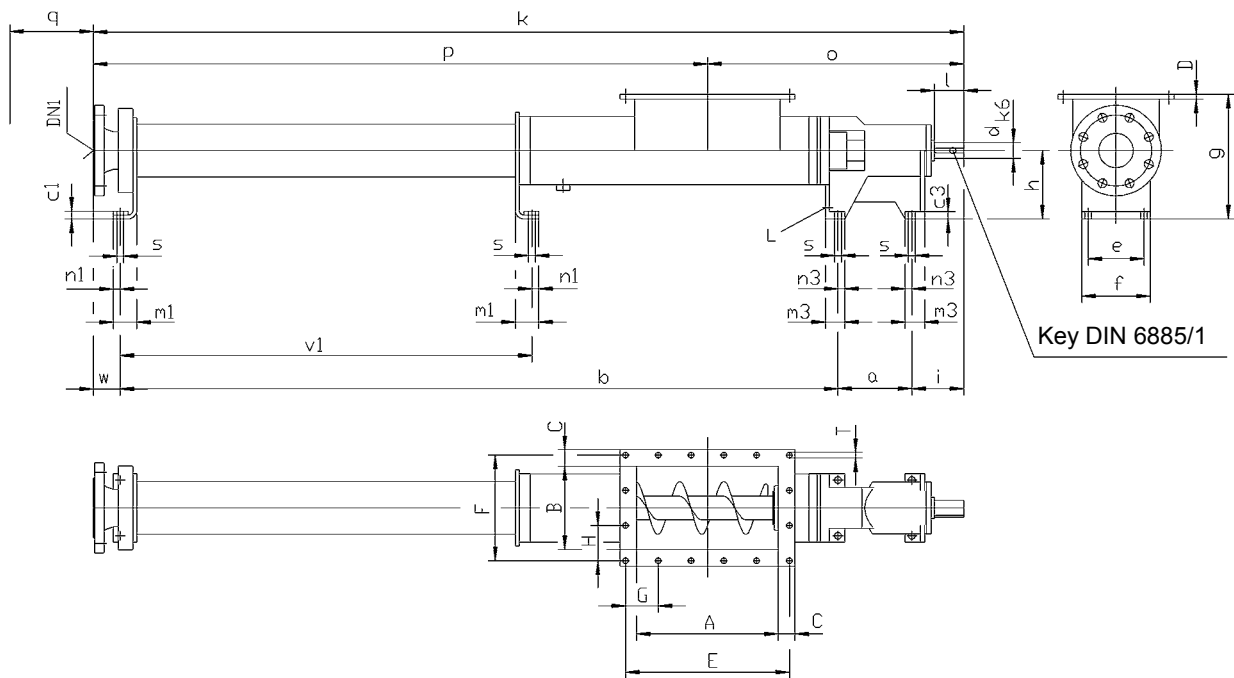

Dimensions in mm, standard widths of the ANSI flanges (DN) in inches.
Subject to change.

Type	Pump dimensions																				
	a	b	c1	c3	d	e	f	g	h	i	l	m1	m3	n1	n3	o	q ^②	s	v1	L	M ^①
AE 4H 25-ZD	122	956	8	10	22	85	105	190	100	79	40	42	30	11	11	380	465	9	-	Rp $\frac{3}{4}$	
AE 4H 50-ZD	140	1186	13	13	28	100	125	225	125	95	50	48	38	13	13	453	605	11,5	-	Rp $\frac{1}{2}$	
AE 4H 100-ZD	151	1468	16	15	32	114	140	255	140	106	60	48	40	14	14	524	760	14	842	Rp $\frac{3}{4}$	
AE 4H 200-ZD	171	1836,5	16	16	42	132	168	290	160	118	65	50	50	19	19	618,5	970	18	1045	Rp $\frac{3}{4}$	
AE 4H 380-ZD	190	2203,5	16	16	48	164	200	330	180	129,5	75	50	50	19	19	690	1210	18	1286	Rp $\frac{3}{4}$	
AE 4H 750-ZD	220	2838	20	21	60	200	245	395	225	158	90	70	63	23	23	851	1600	22	1699	Rp1	
AE 4H 1450-ZD	266	3542	20	24	75	245	290	445	250	182	110	70	65	23	23	1036	2010	22	2128	Rp1	

Type	Connection dimensions of pressure joint									Connection dimensions of inlet hopper									
	Flanges DIN 2501 PN 40 ^⑥				Flanges ANSI B16.5 class 300 ^③					A	B	C	D	E	F	G	H	T	
	DN1	k	p	w	DN1	k	p	w											
AE 4H 25-ZD	40	1204	824	47	1½"	1226	846	69	200	125	33	10	246	170	82	85	11,5		
AE 4H 50-ZD	50	1469	1016	48	2"	1490,5	1037,5	69,5	244	145	33	10	288	189	72	63	11,5		
AE 4H 100-ZD	65	1780	1256	55	2½"	1804,2	1280,2	79,2	290	170	34	10	335	216	67	72	11,5		
AE 4H 200-ZD	80	2187,5	1569	62	3"	2207,5	1589	82	350	200	44	12	410	258	82	86	14		
AE 4H 380-ZD	100	2597	1907	74	4"	2616	1926	93	410	260	45	12	470	320	94	80	14		
AE 4H 750-ZD	125	3289	2438	73	5"	3319,5	2468,5	103,5	522	300	45	12	581	360	83	90	14		
AE 4H 1450-ZD	150	4067	3031	77	6"	4089	3053	99	630	370	55	12	688	430	86	86	14		

① Maximum mass: kg

② Stator dismantling dimensions

③ Sealing surface: stock finish

⑥ Sealing surface DIN 2526, shape C

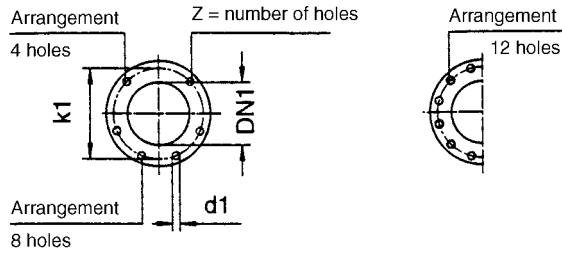

Dimensions in mm, standard widths of the ANSI flanges (DN) in inches.
Subject to change.

Flange dimensions

DIN 2501 PN 16				ANSI B16.1/16.5 Class 125/150				DIN 2501 PN 25/PN 40				ANSI B16.1/16.5 Class 250/300				DIN 2501 PN 40			
DN ₁	k ₁	d ₁	z	DN ₁	k ₁	d ₁	z	DN ₁	k ₁	d ₁	z	DN ₁	k ₁	d ₁	z	DN ₁	k ₁	d ₁	z
40	110	18	4	1½	98,4	15,9	4	40	110	18	4	1½	114,3	22,2	4	200	320	30	12
50	125	18	4	2	120,6	19	4	50	125	18	4	2	127,0	22,2	4				
65	145	18	4	2½	139,7	19	4	65	145	18	8	2½	149,2	22,2	8				
80	160	18	8	3	152,4	19	4	80	160	18	8	3	168,3	22,2	8				
100	180	18	8	4	190,5	19	8	100	190	22	8	4	200	22,2	8				
125	210	18	8	5	215,9	22,2	8	125	220	26	8	5	234,9	22,2	8				
150	240	22	8	6	241,3	22,2	8	150	250	26	8	6	269,9	22,2	12				
200	295	22	12	8	298,4	22,2	8					8	330,2	25,4	12				
250	355	26	12	10	361,9	25,4	12												

Possible connector positions,
seen from the drive

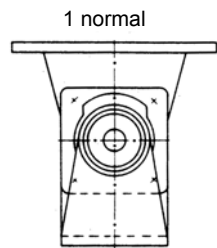

Arrangement of the auxiliary connections for shaft seals AE.N ... -ZD, AE.H ... -ZD

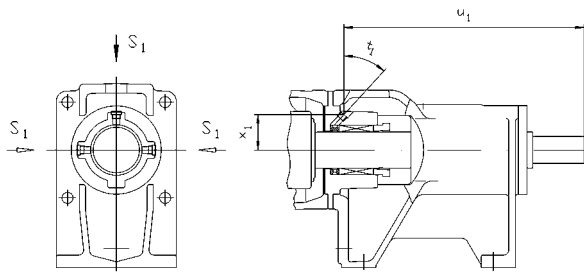

P02, P12 with flushing ring

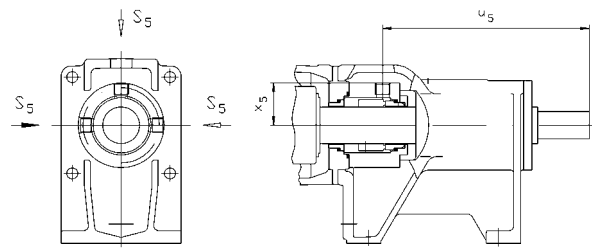

G0S/G0T with flushing connection

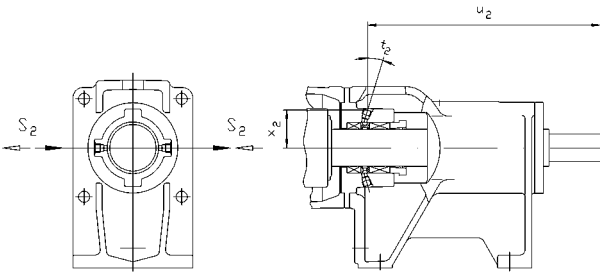

P03, P13 with internal seal chamber ring

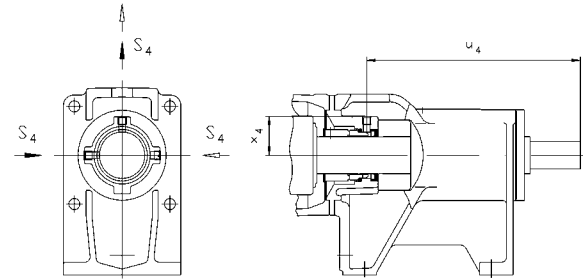

G0Q with quench connection

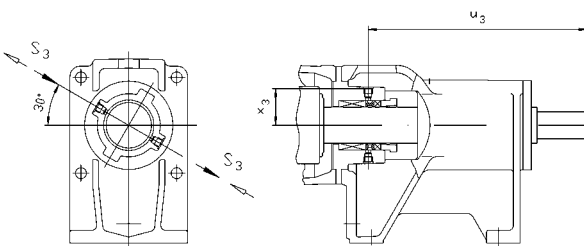

P04, P14 with external seal chamber ring

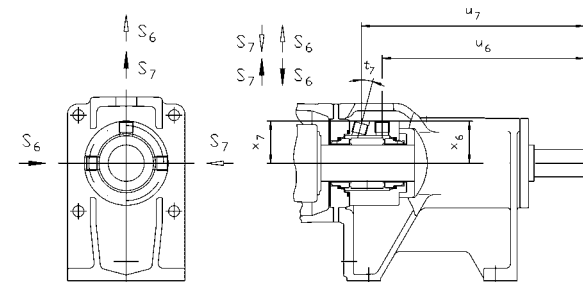

G0D with sealing connection

Series Size	Connection dimensions of auxiliary connections for shaft seals													
	P02, P12 with flushing ring				P03, P13 with internal seal chamber ring				P04, P14 with external seal chamber ring					
	S ₁ ⌀	u ₁	x ₁	t ₁	S ₂ ⌀	u ₂	x ₂	t ₂	S ₃ ⌀	u ₃	x ₃			
	AE.N 25-ZD	M 8 x 1	195.5	28	42°	M 8 x 1	188	30	20°	M 8 x 1	180,5	30,5		
AE.H 25-ZD	AE.N 50-ZD	M 8 x 1	217	31,5	40°	M 8 x 1	211	32	20°	M 8 x 1	202,5	33,5		
AE.H 50-ZD	AE.N 100-ZD	Rp ½	255	38	42°	Rp ½	248	40	17°	Rp ½	236	39,5		
AE.H 100-ZD	AE.N 200-ZD	Rp ½	279	42	42°	Rp ½	272	44	17°	Rp ½	261	43,5		
AE.H 200-ZD	AE.N 380-ZD	Rp ½	316	52	42°	Rp ½	307	54	17°	Rp ½	292,5	54,5		
AE.H 380-ZD	AE.N 750-ZD	Rp ½	349	56	35°	Rp ½	338,5	57	13°	Rp ½	322,5	58		
AE.H 750-ZD	AE.N 1450-ZD	Rp ¼	416	67	35°	Rp ¼	403	68,5	13°	Rp ¼	383	69,5		
AE.H 1450-ZD	AE.N 2700-ZD	Rp ¼	492	77	35°	Rp ¼	474,5	79	13°	Rp ¼	451	80		
AE.H 2700-ZD	AE.N 5000-ZD	Rp ¼	588	94,5	35°	Rp ¼	568,5	97	13°	Rp ¼	542	97		

Series Size	Connection dimensions of auxiliary connections for shaft seals													
	G0S/G0T with flushing connection			G0Q with quench connection			G0D with sealing connection							
	S ₅ ⌀	u ₅	x ₅	S ₄ ⌀	u ₄	x ₄	S ₆ ⌀	S ₇ ⌀	u ₆	u ₇	x ₆	x ₇	t ₇	
	AE.N 25-ZD	Rp ¼	157	34	Rp ½	167	30,5	Rp ¼	Rp ¼	157	182,5	34	33	15°
AE.H 25-ZD	AE.N 50-ZD	Rp ¼	179	38	Rp ½	187,5	30,5	Rp ¼	Rp ¼	179	204,5	38	36,5	15°
AE.H 50-ZD	AE.N 100-ZD	Rp ¼	220,5	41,5	Rp ½	230	33,5	Rp ¼	Rp ¼	220,5	245,5	41,5	40	15°
AE.H 100-ZD	AE.N 200-ZD	Rp ½	241	48,5	Rp ½	255	41	Rp ½	Rp ½	241	266	48,5	47	15°
AE.H 200-ZD	AE.N 380-ZD	Rp ½	280	56	Rp ½	287	54	Rp ½	Rp ½	280	305,5	56	53,5	20°
AE.H 380-ZD	AE.N 750-ZD	Rp ½	297	61	Rp ½	315,5	57,5	Rp ½	Rp ½	297	337,5	61	58,5	20°
AE.H 750-ZD	AE.N 1450-ZD	Rp ¼	364	71,5	Rp ¼	375,5	68,5	Rp ¾	Rp ¾	364	406	71,5	69	22°
AE.H 1450-ZD	AE.N 2700-ZD	Rp ¾	440,5	81	Rp ¾	446	79	Rp ¾	Rp ¾	440,5	479,5	81	78,5	20°
AE.H 2700-ZD	AE.N 5000-ZD	Rp ¾	527	98	Rp ¾	542	96	Rp ¾	Rp ¾	527	576	98	95,5	25°

⊙ Screw-in hole DIN 3852, shape Z

▶ Standard supply

▷ Possible supply, the seal housing must be turned for the versions P02/P12, G0S, G0T, G0Q, G0D.

GB/09.05 – Ident- No. 796 444

Arrangement of the auxiliary connections for shaft seals AEB.N ... -ZE, AEB.H ... -ZE

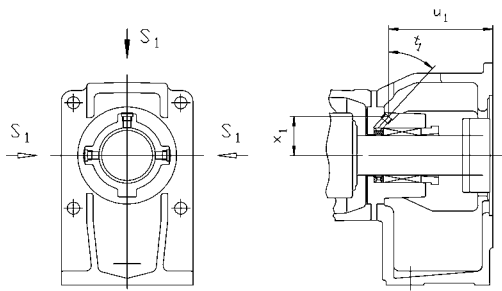

P02 with flushing ring

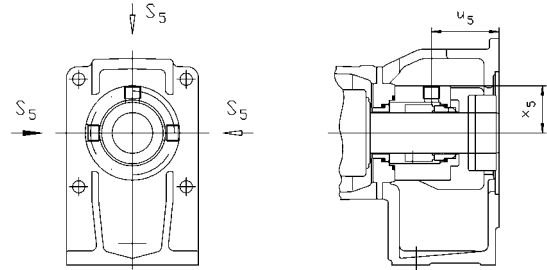

G0S/G0T with flushing connection

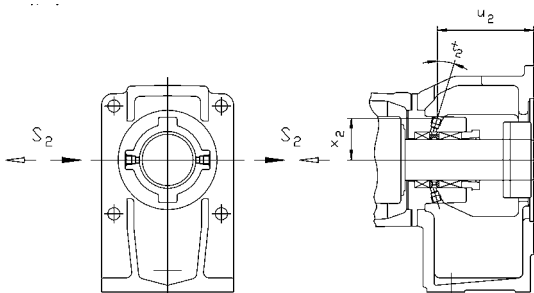

P03 with internal seal chamber ring

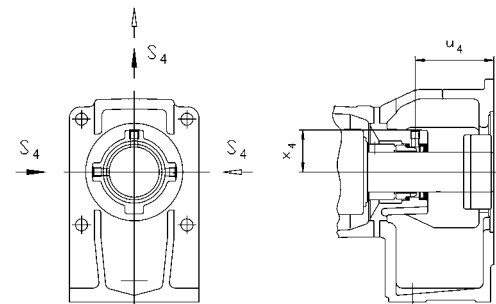

G0Q with quench connection

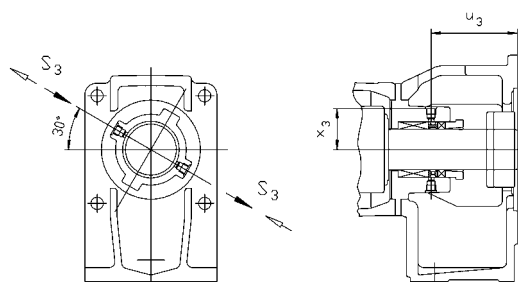

P04 with external seal chamber ring

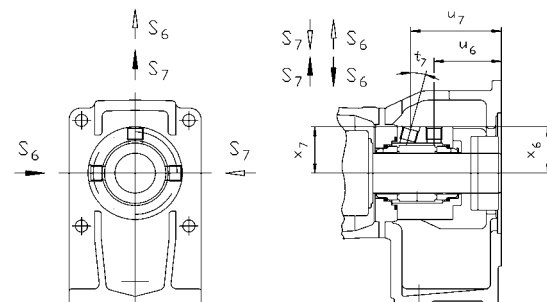

G0D with sealing connection

Series Size		Connection dimensions of auxiliary connections for shaft seals											
		P02 with flushing ring				P03 with internal seal chamber ring				P04 with external seal chamber ring			
		S ₁ ∅	u ₁	x ₁	t ₁	S ₂ ∅	u ₂	x ₂	t ₂	S ₃ ∅	u ₃	x ₃	
	AEB.N 25-ZE	M 8 x 1	84	28	4	M 8 x 1	77	30	20°	M 8 x 1	69	30,5	
AEB 4H	25-ZE	AEB.N 50-ZE	M 8 x 1	93	31,	4	M 8 x 1	87	32	20°	M 8 x 1	78,5	33,5
AEB 4H	50-ZE	AEB.N 100-ZE	Rp 1/8	104,5	38	4	Rp 1/8	97	40	17°	Rp 1/8	85	39,5
		AEB.N 200-ZE	Rp 1/8	109,5	42	4	Rp 1/8	102	44	17°	Rp 1/8	91,5	43,5
		AEB.N 380-ZE	Rp 1/8	128,5	52	4	Rp 1/8	119,5	54	17°	Rp 1/8	105	54,5
		AEB.N 750-ZE	Rp 1/8	133	56	3	Rp 1/8	122,5	57	13°	Rp 1/8	106	58
		AEB.N 1450-ZE	Rp 1/4	155	67	3	Rp 1/4	142	68,5	13°	Rp 1/4	122	69,5

Series Size		Connection dimensions of auxiliary connections for shaft seals													
		G0S/G0T with flushing connection			G0Q with quench connection			G0D with sealing connection							
		S ₅ ∅	u ₅	x ₅	S ₄ ∅	u ₄	x ₄	S ₆ ∅	S ₇ ∅	u ₆	u ₇	x ₆	x ₇	t ₇	
	AEB.N 25-ZE	Rp 1/4	46,5	34	Rp 1/8	56	30,5	Rp 1/4	Rp 1/4	46,5	71,5	34	33	15°	
AEB 4H	25-ZE	AEB.N 50-ZE	Rp 1/4	55	38	Rp 1/8	63,5	30,5	Rp 1/4	Rp 1/4	55	79	38	36,5	15°
AEB 4H	50-ZE	AEB.N 100-ZE	Rp 1/4	69,5	41,5	Rp 1/8	74	33,5	Rp 1/4	Rp 1/4	69,5	95	41,5	40	15°
		AEB.N 200-ZE	Rp 3/8	71,5	48,5	Rp 1/8	79	41	Rp 3/8	Rp 3/8	71,5	96,5	48,5	47	15°
		AEB.N 380-ZE	Rp 3/8	92,5	56	Rp 1/8	99,5	54	Rp 3/8	Rp 3/8	92,5	118	56	53,5	20°
		AEB.N 750-ZE	Rp 3/8	80,5	61	Rp 1/8	99	57,5	Rp 3/8	Rp 3/8	80,5	121	61	58,5	20°
		AEB.N 1450-ZE	Rp 3/8	103	71,5	Rp 1/4	106,5	68,5	Rp 3/8	Rp 3/8	103	145	71,5	69	22°

∅ Screw-in hole DIN 3852, shape 2

▶ Standard supply

▷ Possible supply, the seal housing must be turned for the versions P02, G0S, G0T, G0Q, G0D

Drive options AE.N ... -ZD, AE.H ... -ZD

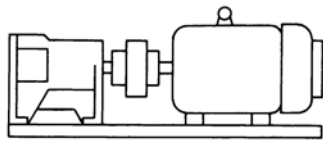

1 with flexible coupling and motor

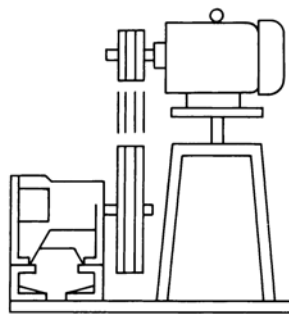

4 with V-belt drive, rocker and motor, arranged behind the pump

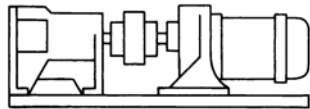

2 with flexible coupling and geared motor

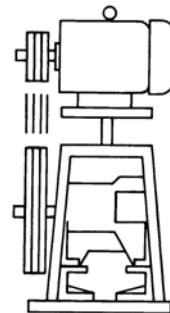

5 with V-belt drive, rocker and motor, arranged above the pump

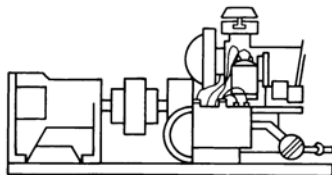

3 with flexible coupling and combustion engine

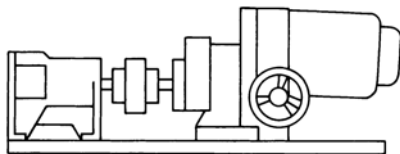

6 with flexible coupling and infinitely variable gear

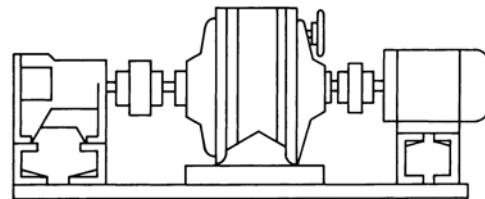

7 with flexible coupling, gear or variable speed gear, flexible coupling and motor

Other drive variations (such as hydraulic or pneumatic drives) are possible

Drive options AEB.N ... -ZE, AEB.H ... -ZE

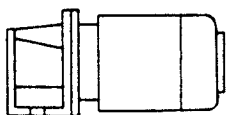

1 with electric motor

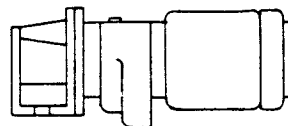

2 with gear motor

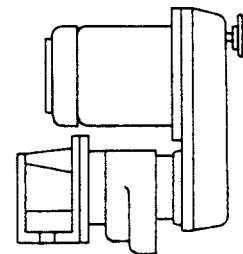

6 with infinitely variable gear

Standard eccentric screw pumps	Series	Number of stages	Max. flow rate at $\Delta p = 0$ bar		Max. pump pressure bar	Max. viscosity mPa·s
			m ³ /h	l/min		
TECFLOW	1		186	3100	4	200,000
AE.E-ID	1,2		450	7500	10	300,000
AE.N-ID	1,2		290	4850	16	270,000
AE.H-ID	2,4		174	2900	24	270,000
AEB.E-IE	1,2		174	2900	6	300,000
AEB.N-IE	1,2		111	1850	12	270,000
AEB4H-IE	4		12	200	24	270,000
AED.E-ID	1		720	12000	8	250,000
AED.N-ID	2		450	7500	16	225,000
AEDB.E-IE	1		258	4300	6	250,000
AEDB.N-IE	2		174	2900	12	225,000
AE.N...-RG	1,2,4		30	500	20	1,000,000
AE.N-ZD	1,2		102	1700	18	1,000,000
AE.H-ZD	1+1, 2, 2+2, 4		60	1000	36	1,000,000
AEB.N-ZE	1,2		45	750	12	1,000,000
AEB.H-ZE	4		3,3	55	24	1,000,000
SEZP	1,2		21	350	10	1,000,000
SSP	1,2		48	800	12	150,000
SSBP	1,2		48	800	12	150,000
SETP ①	1,2		140	2350	10	300,000
SETBP	1,2		40	670	10	150,000
SEFBP	1		40	670	6	150,000
SMP	1		40	670	6	150,000
SMP2	1		5,5	92	6	11,500
AFP	1		2,8	47	6	50,000
ANP	2		2,5	42	12	20,000
ANBP	2		2,5	42	12	20,000
ASP	2		2,5	42	12	20,000
ASBP	2		2,5	42	12	20,000
ADP	3		0,6	10	12	20,000
ADBP	3		0,6	10	12	20,000
ACNP	1,2		29	480	12	150,000
ACNBP	1,2		29	480	12	150,000

① Special higher-pressure version available

Standard peristaltic pumps	Series	Max. flow rate		Max. pump pressure bar	Max. viscosity mPa·s
		m ³ /h	l/min		
ASL		2,4	40	4	100,000
ASH		60	1000	15	100,000

Standard macerators	Series	Max. flow volume	Intrinsic pump
		m ³ /h	m
AM...S-1		80 at 3% TS	3
ABM...S-1		80 at 3% TS	3
AM...I-1		160 at 3% TS	-
ABM...I-1		80 at 3% TS	-

Accessories

Pump accessories: Status adjustment equipment, electric heating devices, bridge breakers
Drives: Electric motors, gear motors, adjustable gears, reduction gears, internal combustion engines, pneumatic and hydraulic drives
Power-transferring parts: Couplings, belt drives, toothed belt drives, other transmission devices
Base plates: Standard and special versions available, mobility equipment, assembly flanges
Safety devices: Bypass lines with safety and control valves, dry-running protection systems (conductive, capacitive, thermal, etc.)
System accessories: Electric, hydraulic, or pneumatic control devices; collector systems, metering equipment, barrier fluid and circulation systems for shaft seals, fittings, flanges, hoses

Subject to technical alterations.



A Colfax Business Unit

ALLWEILER AG
Business Unit Eccentric Screw Pumps
Postfach 200123 · 46223 Bottrop
Kirchhellener Ring 77-79 · 46244 Bottrop
Germany

Tel. +49 (0)2045 966-60
Fax. + 49 (0)2045 966-679
E-Mail: service-ge@allweiler.de
Internet: <http://www.allweiler.com>

GB/09.05 – Ident- No. 796 444