

# Eccentric Screw Pumps in Block Design

**ALLTRI**

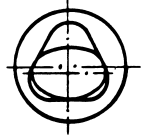

## Series AEDB2N Design IE

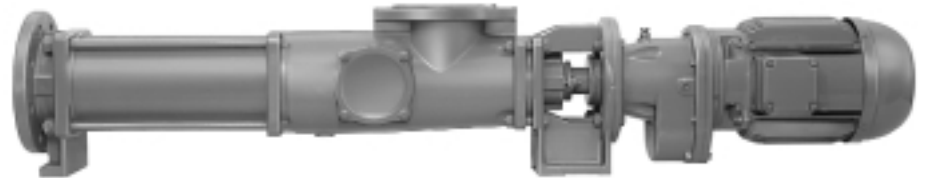

### Application

For handling liquid to highly viscous, neutral or aggressive, uncontaminated or abrasive liquids, liquids containing gases or which tend to froth, also containing fibers and solid matter.

In waste water and waste water treatment engineering, chemical and petrochemical industry, paper and cellulose industry, soap and fats industry, paint and lacquer industry, food and beverage industry, plastics industry, ceramics industry, agriculture, sugar industry and in shipbuilding.

### Operating

Self-priming, two-stage, rotary positive displacement pump. Conveying elements are the rotating screw (rotor) and the fixed stator. In the cross-sectional plane, both are in contact with one another at three points forming three sealing lines along the length of the conveying elements. The contents of the sealed chambers which are formed as the rotor turns, are displaced axially and with complete continuity from the suction to the delivery end of the pump. Despite rotor rotation, there is no turbulence. The constant chamber volume excludes squeezing, thus ensuring an extremely gentle low-pulsating delivery.

### Design features

The pump and drive are held together by the bearing bracket to form a modular unit.

By means of external casing connecting screws (clamping screws), the pressure casing, stator and suction casing are interconnected. The suction casings are designed particularly favorable to flow. The pump sizes 150 to 2300 are supplied in cast iron and are provided with staggered holes for cleaning. The stator vulcanized into a tube or shell casing (even elastomer wall thickness) is provided with external collars vulcanized to it on both sides, reliably sealing towards the suction casing and delivery casing and protecting the stator shell from corrosion.

The exchangeable shaft sealing housing or mechanical seal housing (subsequent conversion to another sealing variant is possible) are arranged between the suction casing and bearing bracket.

The torque of the drive is transmitted over the driving shaft and the joint shaft onto the rotor. On both sides, the joint shaft ends in liquid-tight encapsulated bolt joints, which are of particularly simple and sturdy design and easily absorb the eccentric movement of the rotor.

### Shaft seal

By uncooled, cooled or heated stuffing box or by uncooled or cooled maintenance-free unbalanced, single or double-acting mechanical seal.

Material pairing and design are adapted to the respective operating conditions. For further data, refer to pages 4, 5.

The stuffing box or mechanical seal housings of the various shaft sealing types are interchangeable within one size. The various mechanical seal housing parts form a modular construction system and, in case of conversion to a different mechanical seal design, can be easily combined with one another.

Installation spaces for mechanical seals according to DIN 24 960 (except for double mechanical seal).

For further information, refer to pages 4, 5, 6 and 7.

### Technical data

Deliveries, admissible speed ranges and required drive powers are to be taken from the performance graph on page 3 and/or the separate individual characteristic curves.

				AEDB2N
Delivery	Q	l/min	to	2900
Temperature of fluid pumped	t	°C ①	to	100
Delivery pressure two-stage	Δp	bar	to	12
Pump outlet pressure	p <sub>d</sub>	bar ②	to	16
Attainable underpressure	p <sub>s</sub>	bar ③	to	0.95
Viscosity	η	mPa·s	to	225.000 ③
Admissible solids content	vol% ③		to	60

The mentioned performance data are to be considered as a product and performance abstract only. The particular operating limits can be taken from the quotation or order acknowledgement.

### Max. admissible grain sizes and fiber lengths

Size	38	75	150	300	560
max. grain size mm	3	4	5	6.3	8
max. fiber length mm	42	42	48	60	79

Size	1200	2300
max. grain size mm	10	12.5
max. fiber length mm	98	130

Increasing solids content and increasing grain size require a reduction of the pump speed:

- ① depending upon the fluid to be pumped and the elastomers employed
- ② depending on the direction of rotation, inlet pressure
- ③ depending on the pump size/design, speed and fluid to be pumped

**Bearings**

The driving and the joint shaft are situated in the reinforced bearings of the electric motors, gear motors or control gear which also absorb the generated axial forces.

**As all drives are only supplied with reinforced bearings it must be assured that the assigned pumps can be run at full capacity within their permissible application limits.**

**Drive**

The drive can be provided by non-explosion-proof or explosion-proof three-phase motors, gear motors or control gear. For drive options see page 12. For technical data and dimensions, please refer to the separate sales documentation, data sheet 19-00-0000-111-3.

**A considerable advantage is the fact that within a pump size the connection dimensions for all drive types are the same. This allows a later change to a different drive type or size.**

**Installation**

AEDB pumps may be installed horizontally or vertically. In case of vertical arrangement, "shaft shank downwards" is not admissible.

**Exchangeability of components**

The components of all eccentric screw pumps are of a modular design. This allows a simple and cost-effective spare parts management even if different series and designs of pumps are used.

**Performance graph**

For a rough selection of the pump size and speed as a function of the requested delivery and kind of fluid to be pumped.  $V_{g,m^*}$  = available, mean sliding speed of the rotor in the stator.

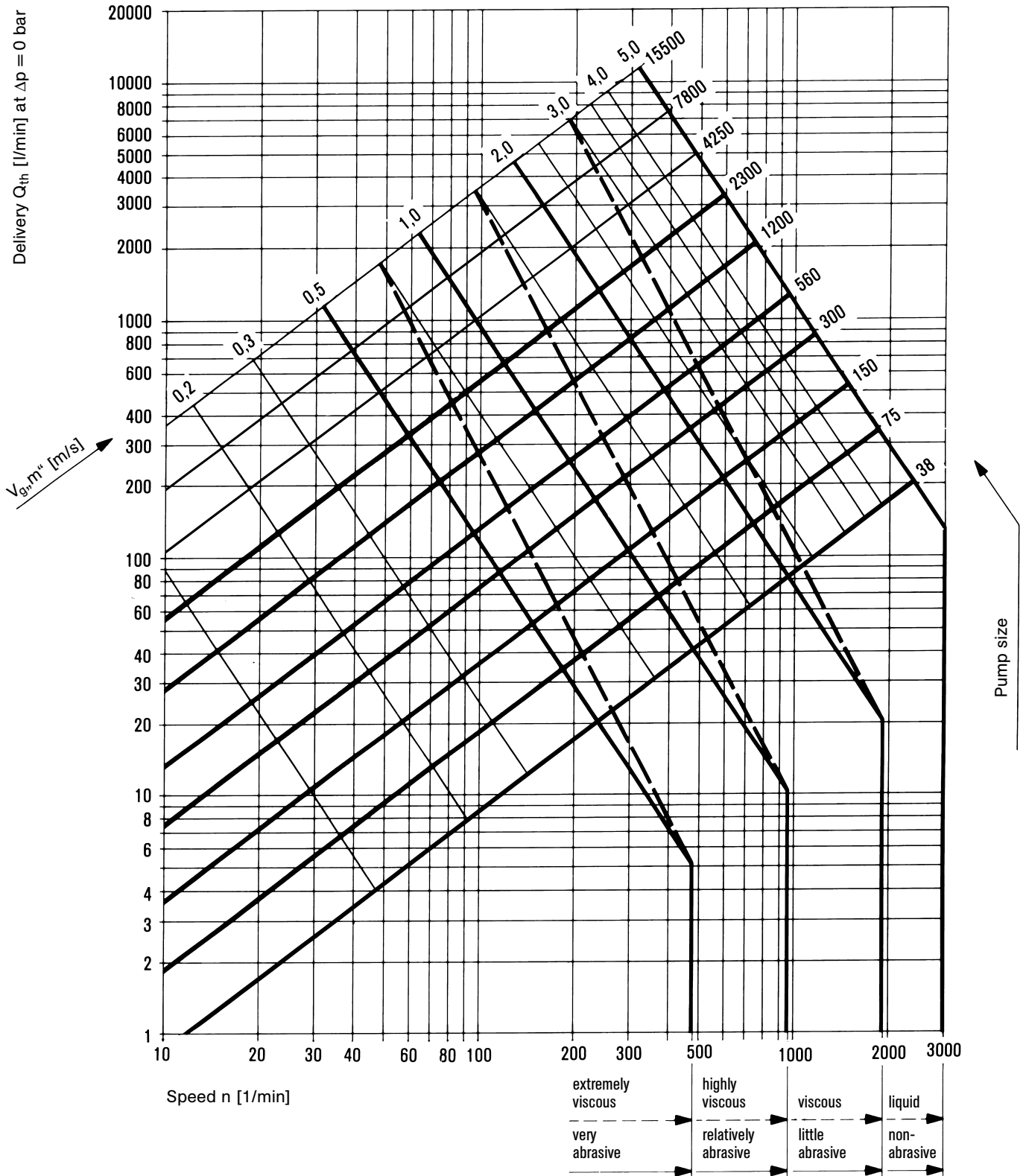

Sizes of the series AEDB2N. Data on the performance range not covered by AEDB2N series are to be taken from the last page of this brochure and/or the individual brochures of the other series.  
For exact performance data, please refer to the individual characteristics.

**Type code**

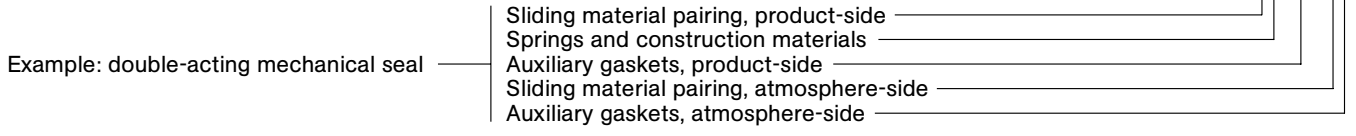
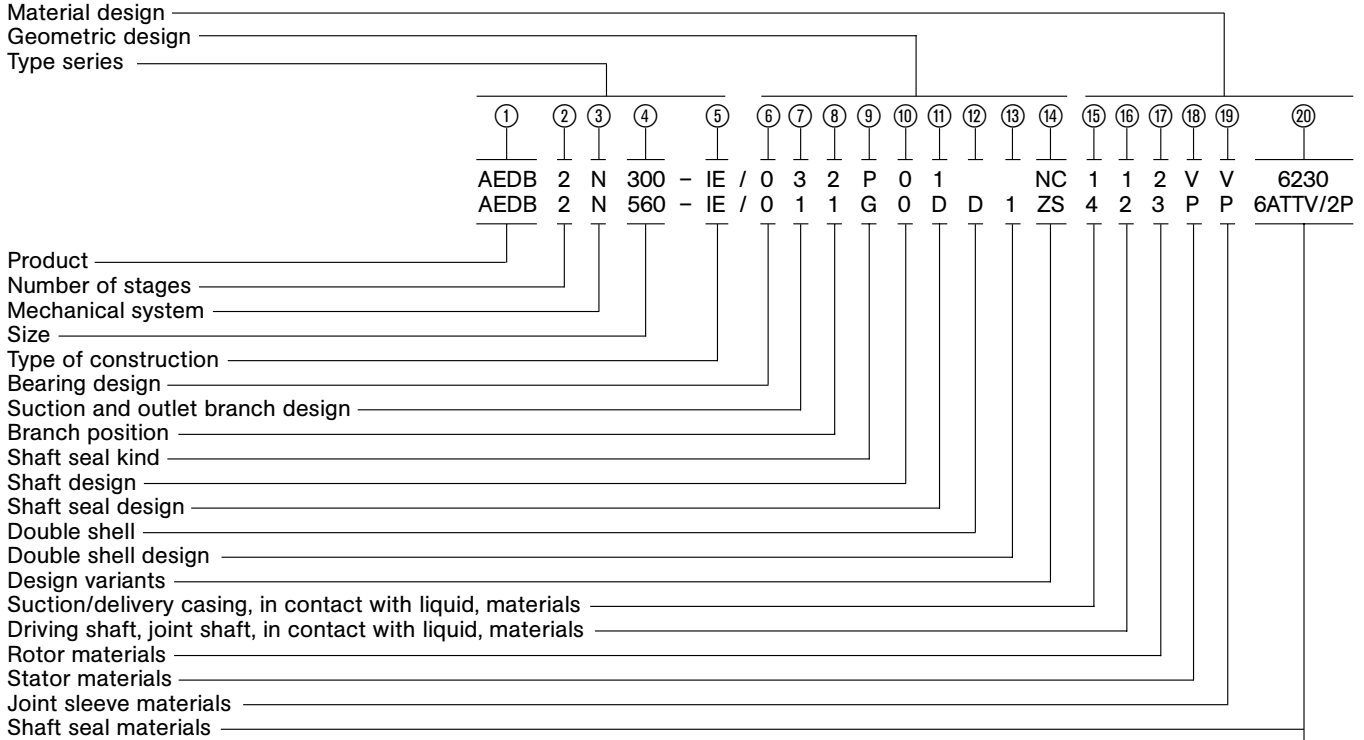

Explanations to the type code:

Position in type code	Designation	Design
①	Product	ALLWEILER eccentric screw pumps – ALLTRI
②	Number of stages	2 = two-stage up to delivery pressure $\Delta p$ 12 bar
③	Mechanical system	N = rated for delivery pressure $\Delta p$ 12 bar
④	Size	Possible sizes: 38, 75, 150, 300, 560, 1200, 2300. The numbers indicate the theoretic delivery in l/min with $n = 400$ 1/min and $\Delta p = 0$ bar
⑤	Design	IE = Industrial design with external bearing
⑥	Bearing design	0 = external bearing in drive unit
⑦	Suction and outlet branch design	1 = DIN flanges 3 = ANSI flanges X = Suction and/or delivery branch of special design } according to dimensional sheet, pages 9 and 10
⑧	Branch position	1, 2, 3, 4 – For arrangement please refer to the representation, page 9. Arrangement 3 is not possible for size 38.
⑨	Shaft seal type	P = Stuffing box or other non-mechanical shaft seal G = Mechanical seal (mechanical shaft seal)
⑩	Shaft design	0 = Shaft without shaft sleeve
⑪	Shaft seal design	Stuffing boxes P01 = Stuffing box of normal design (without sealing chamber ring / without flushing ring) P02 = Stuffing box with flushing ring P03 = Stuffing box with internal sealing chamber ring P04 = Stuffing box with external sealing chamber ring POX = Non-mechanical shaft seal of special design

⑪	Shaft seal design (continued) X = design possible	Mechanical seals									
		for pump sizes	38	75	150	300	560	1200	2300		
		Shaft diameter at the location of the shaft seal	25	30	35	43	53	60	75		
		GOK = individual mechanical seal, DIN 24 960, design K, shape U	X	X	X	X	X	X	X		
		GON = as above, however design N	X	X	X	X	X	X	X		
		GOS = individual mechanical seal, DIN 24 960, design K, shape U, rotating part with integrated locking device and pump-sided throttling ring	X	X	X	X	X	X	X		
		GOT = as above, however design N	X	X	X	X	-	X	X		
		GOQ = individual mechanical seal, DIN 24 960, design K, shape U with quench	X	X	X	X	X	X	X		
		GOD = double mechanical seal	①	①	①	①	①	①	①		
		GOX = mechanical seal of special design									
① design available on request											
⑫	Double shell	D = Double shell for heating/cooling, available in stainless steel only. Connections as threaded nipples for liquid media. Maximum heating/cooling pressure 6 bar, maximum heating temperature +100°C, maximum cooling temperature -40°C									
⑬	Double shell design	1 = Suction case with double shell 2 = Stuffing box for P01 with double shell 12 = Suction and shaft sealing housing P01 with double shell X = Special design for other double shells									
⑭	Design variants	Stators (all qualities)									
		<table border="0"> <tr> <td>N</td> <td rowspan="4">} Rotor with temperature play as a function of the temperature of the fluid pumped</td> </tr> <tr> <td>M</td> </tr> <tr> <td>H</td> </tr> <tr> <td>T</td> </tr> </table>							N	} Rotor with temperature play as a function of the temperature of the fluid pumped	M
N	} Rotor with temperature play as a function of the temperature of the fluid pumped										
M											
H											
T											
		J = Rotor hollow	S = Worm on joint shaft								
		C = Rotor hard chromium-plated	W = Winding protection on joint shaft								
		Y = Rotor ductile hard chromium-plated	X = other designs								
		Z = Rotor metallically coated									
⑮	Suction and delivery casing in contact with fluid, materials	1 = gray cast iron EN-GJL-250 3 = gray cast iron EN-GJL-250, inside H-rubberized 4 = 1.4408/1.4571 A = 1.4462 X = Special materials									
⑯	Driving shaft, joint shaft casing in contact with fluid, materials	1 = 1.4021 2 = 1.4301/1.4571/1.4462 4 = 1.4571/1.4462 A = 1.4462 X = Special materials, i.e. also for articulated components									
⑰	Rotor materials	2 = 1.4301	4 = 1.4571	A = 1.4462							
		3 = 1.2436/1.2379	X = Special materials, e.g. other metals, plastic materials								
⑱	Stator materials	WB = Caoutchouc soft/butadiene (NR/BR)	V = Viton (FPM)	PU = Polyurethan							
		P = Perbunan N (NBR)	HP = Perbunan	E = EPDM							
		Y = Hypalon (CSM)	SL = Silicon bright (MVQ)	X = Special materials							
⑲	Joint sleeve materials	P = Perbunan N (NBR)	Y = Hypalon (CSM)	X = Special materials							
		PL = Perbunan bright (NBR)	V = Viton (FPM)								
		N = Neoprene (CR)	B = Butyl caoutchouc (IIR)								
⑳	Shaft seal materials	Stuffing box: 5846 = Ramie fiber with PTFE impregnation, asbestos-free 6426 = Aramid endless fiber with PTFE impregnation, asbestos-free 6230 = Graphite-incorporated PTFE with sliding means, asbestos-free									
		Mechanical seal:									
		Sliding material pairing		Spring and constr. materials		Auxiliary gaskets					
		1st point for single gasket 1st + 4th point for double gasket		2nd point		3rd point for single gasket 3rd + 5th points for double gasket					
		2 = CrMo cast iron/hard carbon 4 = Ceramics/hard carbon 5 = Hard metal/hard metal, highly wear-resistant 6 = Silicon carbide/silicon carbide highly wear-resistant, corrosion-resistant 7 = Silicon carbide/silicon carbide highly wear-resistant, highly corrosion-resistant X = Special materials		A = 1.4300 F = 1.4571 L = Hastelloy B M = Hastelloy C4 X = Special materials		P = Perbunan E = EP caoutchouc S = Silicon caoutchouc N = Neoprene V = Viton TTE = EP caoutchouc ① TTV = Viton ① TTS = Silicon caoutchouc ① X = Special materials					

Sectional drawing and components list

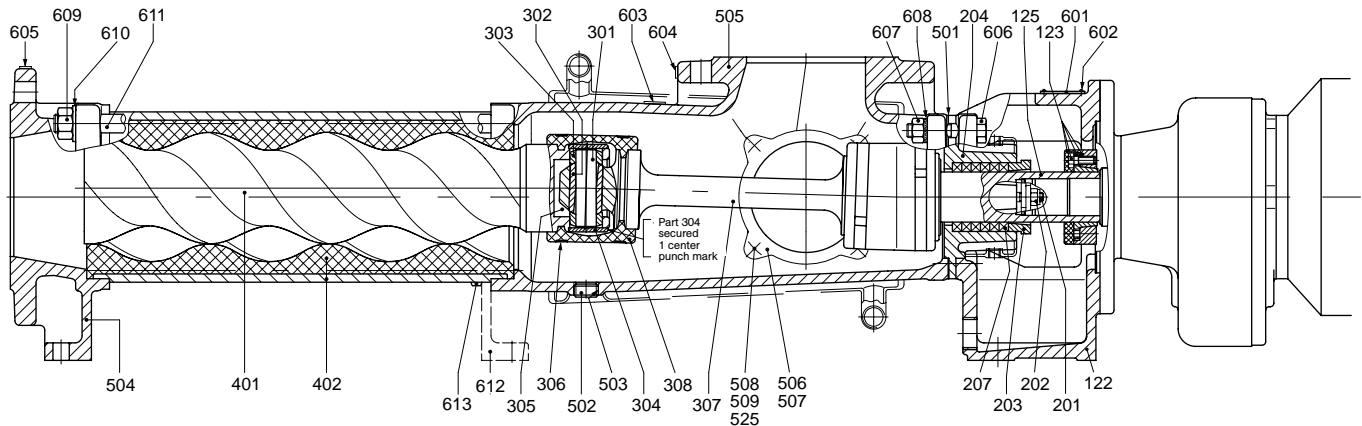

Bearing **0**: External bearing in drive unit  
 Shaft seal **P01**: Due to particularly great packing length, versatile, admissible pressure at the shaft seal  $p = -0.7$  to 16 bar

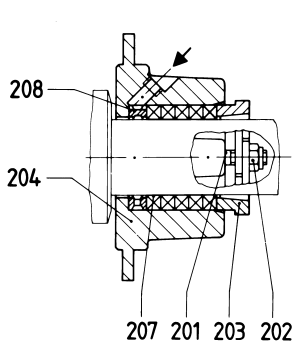

**P02** Stuffing box with flushing ring

To be employed for very abrasive fluids pumped with external flushing  
 $p = -0.7$  to 12 bar

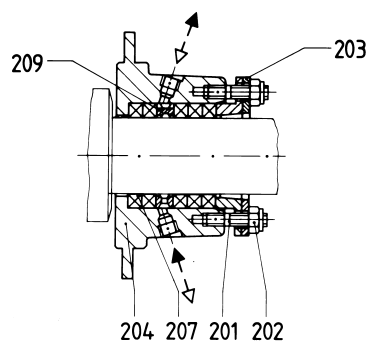

**P03** Stuffing box with internal sealing chamber ring

To be employed for pure fluids with internal sealing or for abrasive fluids with external sealing  
 $p = -0.8$  to 6.0 bar

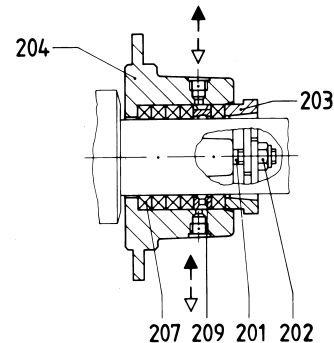

**P04** Stuffing box with internal sealing chamber ring

To be employed in case of incompatibility of the external sealing liquid with the fluid pumped or if air inlet is to be avoided  
 $p = -0.9$  to 12 bar

Part No.	Name	Part No.	Name	Part No.	Name
122	Bearing bracket	215	Mechanical seal cover	304	Joint sleeve
123	Tensioning set	218	O-ring	305	Joint lubricant
125	Driving shaft	219	Mechanical seal	306	Joint clamp
201	Stud bolt	220	Locking pin	307	Joint shaft
202	Self-locking nut	232	Shaft seal ring	308	Joint collar
203	Gland half	234	Throttling ring	401	Rotor
204	Shaft sealing housing	235	O-ring	402	Stator
207	Stuffing box	236	Locking pin	403	Stator gasket delivery-side
208	Flushing ring	245	Hexagon screw	404	Stator gasket suction-side
209	Sealing chamber ring	251	Sealing compound	501	Gasket for suction casing
212	Screw plug	301	Joint bolt	502	Screw plug
213	Joint tape	302 ①	Joint bush	503	Joint tape
214	Mechanical seal housing	303	Bush for joint bolt	504	Delivery casing

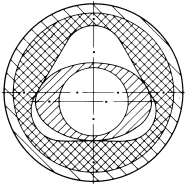

**Geometry of pump elements**  
series AEDB2N

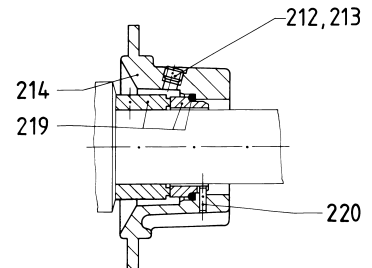

**GOK/GON** Single mechanical seal,  
DIN 24 960, K/N design, U shape.  
For employment, please inquire,  
 $p = -0.5$  to 16 bar

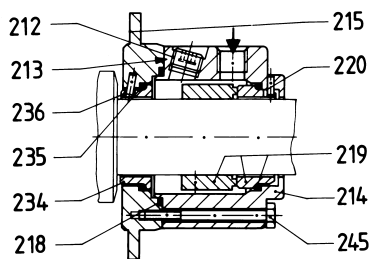

**GOS/GOT** Single mechanical seal,  
DIN 24 960, K/N design, U shape.  
Integrated locking device with  
flushing liquid connection and  
pump-side throttling ring.  
For employment, please inquire,  
 $p = -0.5$  to 16 bar

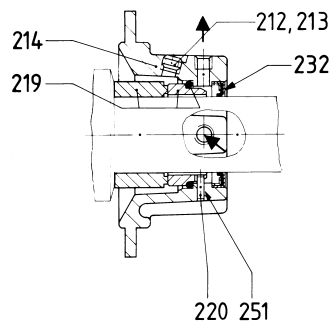

**GOQ** Single mechanical seal,  
DIN 24 960, K design, U shape  
with quench.  
For employment, please inquire,  
 $p = -0.5$  to 16 bar

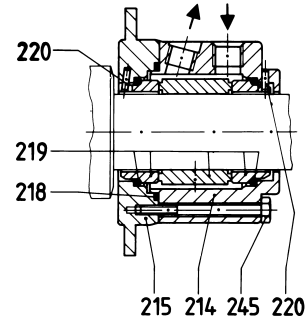

**GOD** Double mechanical seal  
with sealing liquid connection.  
For employment, please inquire,  
 $p = -0.95$  to 16 bar

Part No.	Name
505	Suction casing
506	Suction casing cover
507	Gasket
508	Stud bolt
509	Hexagon nut
525	Washer
601	Type plate
602	Round head grooved pin
603	Information plate commissioning
604	Information plate suction
605	Information plate pressure
606	Hexagon screw

Part No.	Name
607	Hexagon nut
608	Fan-type lock washer
609	Hexagon nut
610	Washer
611	Clamp bolt
612	Support
613	Hexagon screw

① not applicable for size 38

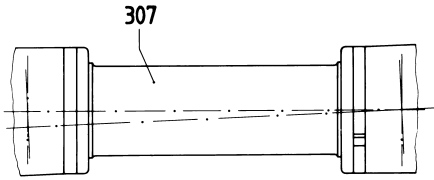

Winding protection on joint shaft

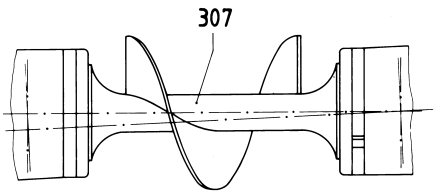

Worm on joint shaft



**Pump dimensions, auxiliary connections, possible branch positions, weights**

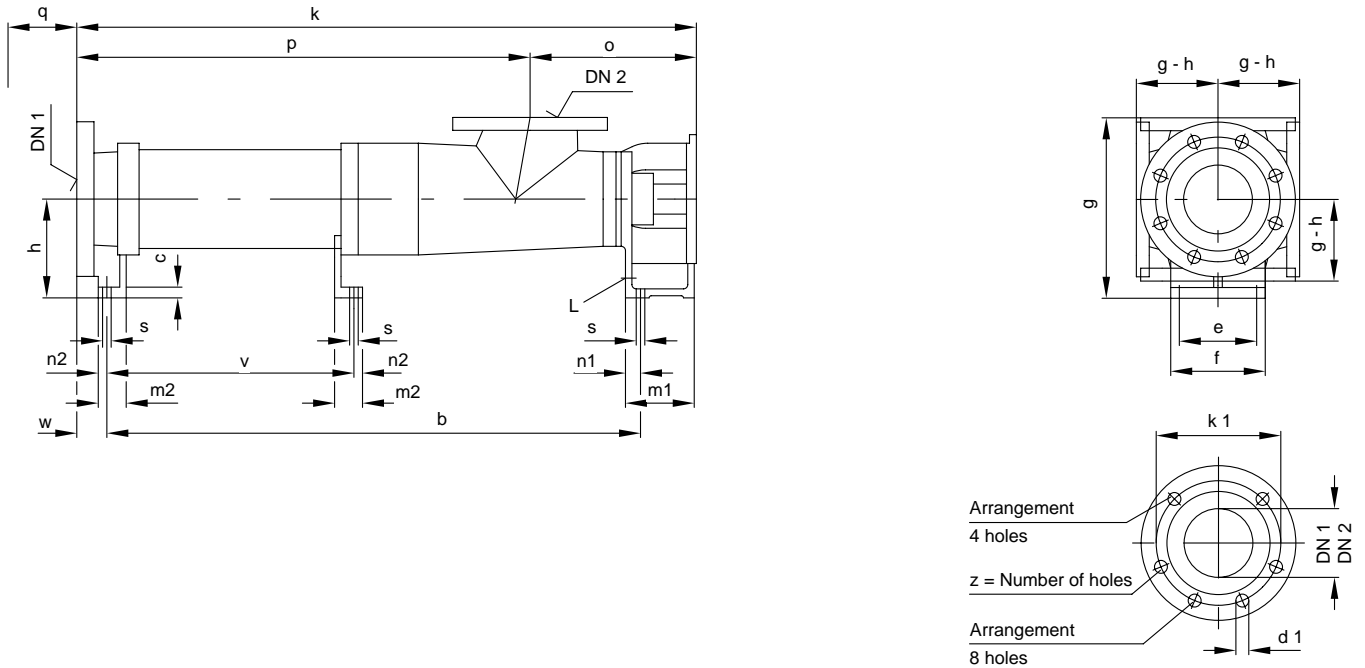

Dimensions in mm, nominal width of ANSI flanges (DN) in inches. Subject to alteration.

Sense of rotation: normally counter-clockwise as seen from the, driving side with DN<sub>1</sub> = outlet branch, DN<sub>2</sub> = suction branch, change of rotation possible, then, DN<sub>1</sub> = suction branch, DN<sub>2</sub> = outlet branch

Series Size	Pump dimensions														Max. mass kg
	b	c	e	f	h	m <sub>1</sub>	m <sub>2</sub>	n <sub>1</sub>	n <sub>2</sub>	o	① q	s	L	v	
AEDB2N 38-IE	530	10	75	95	90	84	30	19	11	162	230	9	Rp 3/8	-	
AEDB2N 75-IE	650	10	85	105	100	93	30	19	11	185	305	9	Rp 3/8	-	
AEDB2N 150-IE	820	13	100	125	125	106	38	25	13	220	395	11.5	Rp 1/2	-	
AEDB2N 300-IE	991	15	114	140	140	110	40	26	14	241.5	500	14	Rp 3/4	-	
AEDB2N 560-IE	1197.5	16	132	168	160	128	50	31	19	292	625	18	Rp 3/4	-	
AEDB2N 1200-IE	1517.5	16	164	200	180	131	50	31	19	316	830	18	Rp 3/4	-	
AEDB2N 2300-IE	1876	21	200	245	225	153	63	40	23	383	1040	22	Rp 1	1147	

① Stator dismantling dimension

**Possible branch positions as seen from the drive**

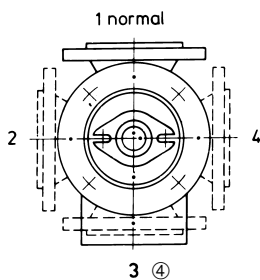

④ not for series/size AEDB2N 38-IE

Flange dimensions							
DIN 2501, PN 16 ⑤				ANSI B16.1/16.5, Class 125/150 ③			
DN <sub>1</sub> /DN <sub>2</sub>	k <sub>1</sub>	d <sub>1</sub>	z	DN <sub>1</sub> /DN <sub>2</sub>	k <sub>1</sub>	d <sub>1</sub>	z
40	110	18	4	1 1/2	98.4	15.9	4
50	125	18	4	2	120.6	19	4
65	145	18	4	2 1/2	139.7	19	4
80	160	18	8	3	152.4	19	4
100	180	18	8	4	190.5	19	8
125	210	18	8	5	215.9	22.2	8
150	240	22	8	6	241.3	22.2	8

Series Size	Connection dimensions for suction and outlet branch																	
	Flanges DIN 2501, PN 16 ⑤						Flanges ANSI B16.1, Class 125 ③						Flanges ANSI B16.5, Class 150 ③					
	DN <sub>1</sub>	② DN <sub>2</sub>	② k	② p	② w	g	DN <sub>1</sub>	DN <sub>2</sub>	② k	② p	② w	② g	DN <sub>1</sub>	DN <sub>2</sub>	k	p	w	g
AEDB2N 38-IE	40	40	639	477	41	175	1 1/2	1 1/2	636	474	38	172	1 1/2	1 1/2	639	477	41	175
AEDB2N 75-IE	50	50	770	585	43	190	2	2	766	581	39	186	2	2	770	585	43	190
AEDB2N 150-IE	65	65	944	724	40	230	2 1/2	2 1/2	943	723	39	229	2 1/2	2 1/2	948	728	44	234
AEDB2N 300-IE	80	80	1122.5	881	44	260	3	3	1120.5	879	42	258	3	3	1125.5	884	47	263
AEDB2N 560-IE	100	100	1340	1048	41	300	4	4	1342	1050	43	302	4	4	1342	1050	43	302
AEDB2N 1200-IE	125	125	1665	1349	44	350	5	5	1665	1349	44	350	5	5	1665	1349	44	350
AEDB2N 2300-IE	150	150	2046	1663	53	425	6	6	2046	1663	53	425	6	6	2046	1663	53	425

② for rubber-coating + 3 mm  
③ Sealing surface: stock finish

⑤ up to DN 100 sealing surface DIN 2526 shape C, machined as shape A from DN 125 sealing surface DIN 2526 shape A

**Arrangement of auxiliary connections for shaft seals**

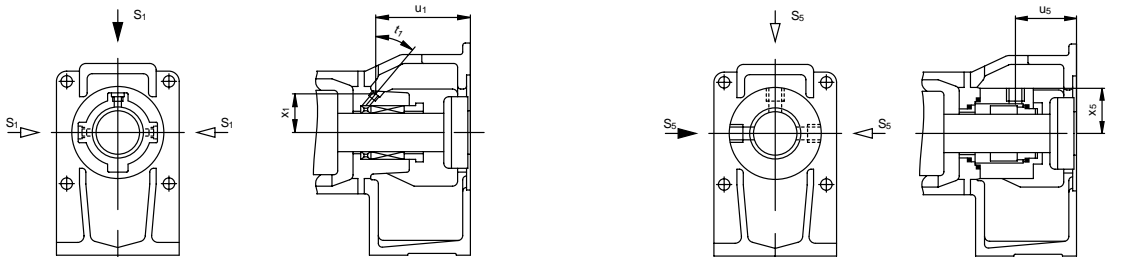

**P02 with flushing rod**

**G0S/G0T with flushing connection**

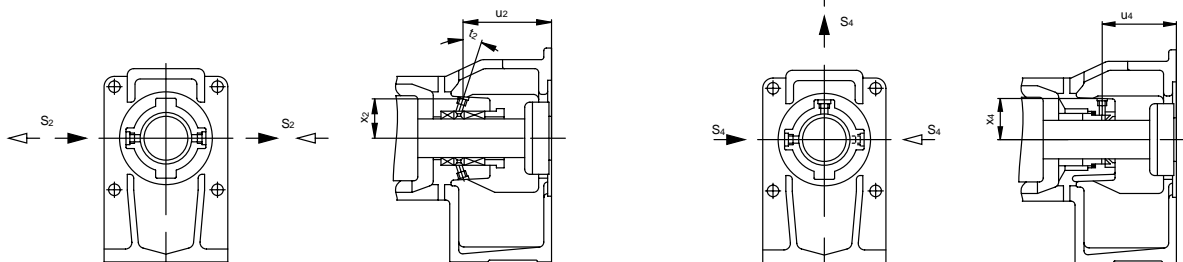

**P03 with internal sealing chamber ring**

**G0Q with quench connection**

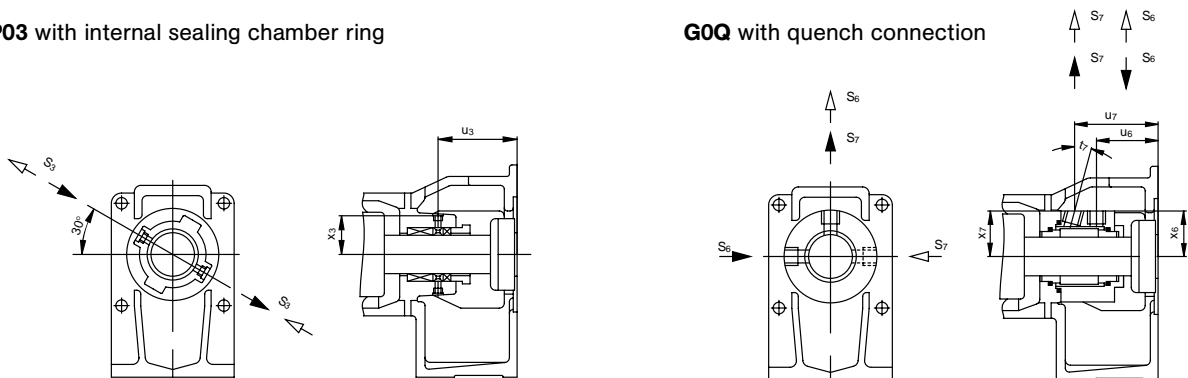

**P04 with external sealing chamber ring**

**G0D with sealing connection**

Series Size	Connection dimensions for auxiliary connections for shaft seals										
	P02 with flushing ring				P03 with internal sealing chamber ring				P04 with external sealing chamber ring		
	S <sub>1</sub> ⑥	u <sub>1</sub>	x <sub>1</sub>	t <sub>1</sub>	S <sub>2</sub> ⑥	u <sub>2</sub>	x <sub>2</sub>	t <sub>2</sub>	S <sub>3</sub> ⑥	u <sub>3</sub>	x <sub>3</sub>
AEDB2N 38-IE	M 8 x 1	84	28	42°	M 8 x 1	77	30	20°	M 8 x 1	69	30.5
AEDB2N 75-IE	M 8 x 1	93	31,5	40°	M 8 x 1	87	32	20°	M 8 x 1	78.5	33.5
AEDB2N 150-IE	Rp 1/8	104.5	38	42°	Rp 1/8	97	40	17°	Rp 1/8	85	39.5
AEDB2N 300-IE	Rp 1/8	109.5	42	42°	Rp 1/8	102	44	17°	Rp 1/8	91.5	43.5
AEDB2N 560-IE	Rp 1/8	128.5	52	42°	Rp 1/8	119.5	54	17°	Rp 1/8	105	54.5
AEDB2N 1200-IE	Rp 1/8	133	56	35°	Rp 1/8	122.5	57	13°	Rp 1/8	106	58
AEDB2N 2300-IE	Rp 1/4	155	67	35°	Rp 1/4	142	68.5	13°	Rp 1/4	122	69.5

Series Size	Connection dimensions for auxiliary connections for shaft seals												
	GOS/GOT with flushing connection			GOQ with quench connection			GOD with sealing connection						
	S <sub>5</sub> ⑥	u <sub>5</sub>	x <sub>5</sub>	S <sub>4</sub> ⑥	u <sub>4</sub>	x <sub>4</sub>	S <sub>6</sub> ⑥	S <sub>7</sub> ⑥	u <sub>6</sub>	u <sub>7</sub>	x <sub>6</sub>	x <sub>7</sub>	t <sub>7</sub>
AEDB2N 38-IE	Rp 1/4	46.5	34	Rp 1/8	56	30.5	Rp 1/4	Rp 1/4	46.5	71.5	34	33	15°
AEDB2N 75-IE	Rp 1/4	55	38	Rp 1/8	63.5	30.5	Rp 1/4	Rp 1/4	55	79	38	36.5	15°
AEDB2N 150-IE	Rp 1/4	69.5	41.5	Rp 1/8	74	33.5	Rp 1/4	Rp 1/4	69.5	95	41.5	40	15°
AEDB2N 300-IE	Rp 3/8	71.5	48.5	Rp 1/8	79	41	Rp 3/8	Rp 3/8	71.5	96.5	48.5	47	15°
AEDB2N 560-IE	Rp 3/8	92.5	56	Rp 1/8	99.5	54	Rp 3/8	Rp 3/8	92.5	118	56	53.5	20°
AEDB2N 1200-IE	Rp 3/8	80.5	61	Rp 1/8	99	57.5	Rp 3/8	Rp 3/8	80.5	121	61	58.5	20°
AEDB2N 2300-IE	Rp 3/8	103	71.5	Rp 1/4	106.5	68.5	Rp 3/8	Rp 3/8	103	145	71.5	69	22°

⑥ Threaded connection DIN 3852, shape Z

- ▶ Standard supply
- ▷ Possible supply. In this case, the sealing housing must be turned for designs P02, G0S, G0T, GOQ, GOD.

**Drive options**

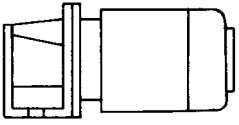

AEDB-IE with electric motor

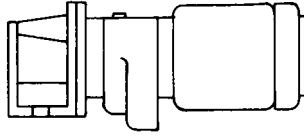

AEDB-IE with gear motor

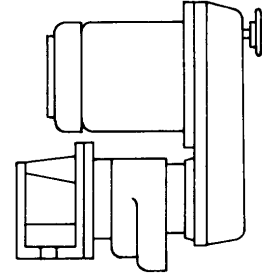

AEDB-IE with infinitely variable gear



Range of eccentric screw pumps	Series	Number of stages	Maximum output at $\Delta p = 0$ bar		Maximum del. pressure bar	Maximum viscosity mPa·s
			m <sup>3</sup> /h	l/min		
	AE.E-ID	1,2	450	7500	10	300.000
	AE.N-ID	1,2	290	4850	16	270.000
	AE.H-ID	2,4	174	2900	24	270.000
	AEB.E-IE	1,2	174	2900	6	300.000
	AEB.N-IE	1,2	111	1850	12	270.000
	AEB4H-IE	4	12	200	24	270.000
	AED.E-ID	1	720	12000	8	250.000
	AED.N-ID	2	450	7500	16	225.000
	AEDB.E-IE	1	258	4300	6	250.000
	AEDB.N-IE	2	174	2900	12	225.000
	AE.N...-RG	1,2,4	30	500	20	1.000.000
	TECFLOW	1	186	3100	4	200.000
	SEZP	1,2	21	350	10	1.000.000
	SNZP	1,2	45	750	12	1.000.000
	SNZBP	1,2	45	750	12	1.000.000
	SSP	1,2	48	800	12	150.000
	SSBP	1,2	48	800	12	150.000
	SETP ①	1,2	140	2350	10	300.000
	SETBP	1,2	40	670	10	150.000
	SEFBP	1	40	670	6	150.000
	SMP	1	40	670	6	150.000
	SMP2	1	5,5	92	6	11.500
	AFP	1	2,8	47	6	50.000
	ANP	2	2,5	42	12	20.000
	ANBP	2	2,5	42	12	20.000
	ASP	2	2,5	42	12	20.000
	ASBP	2	2,5	42	12	20.000
	ADP	3	0,6	10	12	20.000
	ADBP	3	0,6	10	12	20.000
	ACNP	1,2	29	480	12	150.000
	ACNBP	1,2	29	480	12	150.000

① Special versions for higher pressures available.

Peristaltic range	Series	Maximum output		Maximum del. pressure bar	Maximum viscosity mPa·s
		m <sup>3</sup> /h	l/min		
	ASL	2,4	40	4	100.000
	ASH	60	1000	15	100.000

Macerator range	Series	Maximum throughput m <sup>3</sup> /h	Generated delivery head
			m
	AM ... S-1	80 at 3 % solids	3
	ABM ... S-1	80 at 3 % solids	3
	AM ... I-1	160 at 3 % solids	-
	ABM ... I-1	80 at 3 % solids	-

**Accessories**

Pump accessories: Stator setting devices, electrical heaters, bridge breakers.

Drivers: Electric motors, geared motors, variable speed transmissions, reduction gearboxes, internal combustion engines, pneumatic and hydraulic drives.

Transmission components: Couplings, V-belt transmissions, toothed belt transmissions, other types of transmission.

Base plates: Standard and special versions, wheeled trolleys, mounting flanges.

Safety arrangements: Bypass lines with safety or regulating valves, systems to guard against dry running (conductive, capacitive, thermal etc.).

Other accessories: Electrical, hydraulic and pneumatic control arrangements, filter systems, metering equipment, seal liquid and circulating systems for shaft seals, valves, flanges, flexible pipes.

Subject to technical alterations.



A Member of the  
COLFAX PUMP GROUP

**ALLWEILER AG · Werk Bottrop**  
Postfach 200123 · 46223 Bottrop  
Kirchhellener Ring 77-79 · 46244 Bottrop  
Germany  
Tel. +49 (0)2045 966-60  
Fax +49 (0)2045 966-679  
E-mail: service-ge@allweiler.de  
Internet: http://www.allweiler.com