

# Block Macerators Series ABM Designs S and I

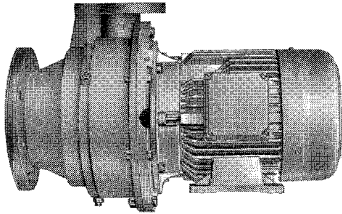

Design S

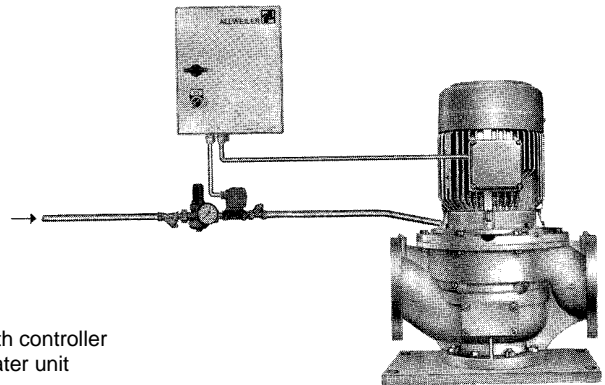

Design I with controller and seal water unit

### Usage

Macerators chop solids conveyed in liquids; materials like wood, textiles, plastics, paper, rubber, bones, skins, glass etc., so that they may be pumped. After treatment solids have a grain size of approx. 3.5 mm and fibres and size of approx. 1.5 cm<sup>2</sup>.

As pieces of metal and stones damage the impeller cutters, a collector should be fitted upstream the macerator in order to catch them.

### Main Fields of Application

Preparation, fine chopping, mixing and processing fields as well as for the treatment of waste products in all branches of industry.

The macerator chops bulky and fibrous parts so that

pipes, fittings and pumps are not clogged, small diameter pipes and fittings may be used, their size only being determined by the flow to be delivered.

Further important applications are in domestic and industrial sewage treatment plants where sludge is treated and processed in various ways. It is economical with any process to chop the relevant solids before treating them any further. Apart from the advantages cited above, the reasons for this are as follows:

The avoidance of excessive wear of the pump elements, decanters and centrifuges.

Easier drainage of thickened sludge which does not contain coarse solids.

Chopped solids have a greater surface area. In this way putrefaction of the sludge occurs quickly and thoroughly.

Easier transportation and scattering of dry sludge in granulated form.

Further fields of application:

Food industry, fish processing, canneries, meat factories, fruit, vegetable and meat processing.	}	Processing and waste treatment
Chemical, petrochemical and pharmaceutical industries, paper and cellulose industry.		Preparation and chopping fields
Animal feedstuffs industry, tanneries, slaughter houses, animal utilizing plants.	}	Processing and waste treatment
Shopping centres, restaurants, hotels, supermarkets, canteens, large kitchens, barracks, boats and ships		Waste treatment

### Block macerator abbreviation system

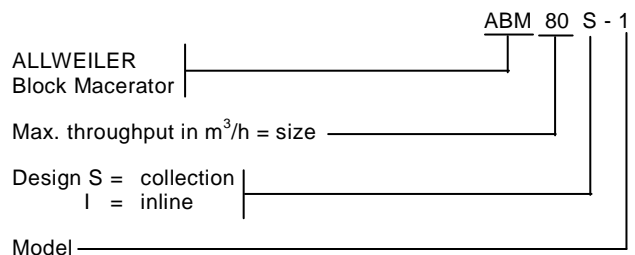

### Design and Operation

Block macerators are supplied in two designs:

**S design:** For installation on the side of a tank or basin. Macerators of this design have a delivery head of 3 m and can thus return the chopped solids to the main flow under their own power.

**I design:** For direct installation in the piping. A helical rotor pump must be installed downstream this design in order to suck the solids through the macerator and pump them into the plant for further treatment.

The macerator casing is connected to the drive motor by means of the sealing cover. A cutting ring is fixed in the macerator casing in which turns the impeller, which is fitted with interchangeable chopping blades. The solids suspended in the delivery medium are caught by the impeller, flung against the cutting ring and chopped into small pieces.

The four interchangeable highly wear resistant impeller blades have symmetrical cutting edges which permit operation with the motor running in either direction. The service life of the cutters is considerably increased as the direction of rotation of the motor is altered each time the motor is switched on.

The drive unit including the sealing cover, mechanical seal, impeller and cutting ring can easily be removed towards the drive side by undoing the bolts. The macerator casing may be left fixed in the piping.

**Nozzle positions**  
**S design**      suction nozzle: axial or vertical downwards  
                   delivery nozzle: normally radial upwards. Adjustable by 45° each as per hole arrangement

**I design**      inlet and outlet nozzles: opposite, inline same DN

**Flanges**  
**For both designs:** Connection dimensions as per DIN 2501, PN 10 or as per ANSI B 16.1 Class 125

## Shaft Sealing

By means of maintenance free mechanical seal with highly wear resistant hard metal seal rings and rubber bellows secondary gasket.

Materials:

rotary seal ring	silicon carbide
stationary seal ring	silicon carbide
bellows	acrylonitrile-butadiene rubbers (NBR)
O-ring	acrylonitrile-butadiene rubbers (NBR)
metal parts	stainless steel

Seal water must be supplied to the mechanical seal at 2 bar above the system pressure.

A sealing water supply unit can be supplied at extra cost.

## Bearing / Lubrication

On the drive side by a reinforced cylinder roller bearing as per DIN 5412 which is greased for its service life. On the end side by a grooved ball bearing as per DIN 625. Axial forces are taken up by the grooved ball bearing.

## Connections

The following connections are always provided:

S design: S1 external sealing fluid for shaft seal.

I design: M1 pressure gauge.

S1 external sealing fluid for shaft seal.

## Drive

Surface cooled threephase A.C. motors, design V1 (macerator design I) and B3/B5 (macerator design S). Enclosure IP 55 as per IEC standards, insulation class B, capacities and main dimensions as per DIN 42 677. However, shaft end and bearings of special design.

## Technical Data

macerator type	cutting ring ø mm	max. throughput at 3% d.s. m <sup>3</sup> /h ②	speed rpm	drive capacity kW	delivery head m	weight kg approx.
ABM 10 S -1	200	10	1500	4,0	3,0	119
ABM 20 S -1	200	20	1500	5,5		121
ABM 40 S -1	300	40	1000	7,5		235
ABM 80 S -1	300	80	1000	11,0		237
ABM 10 I-1	200	10	1500	4,0	-	173
ABM 20 I-1	200	20	1500	5,5		175
ABM 40 I-1	300	40	1000	7,5		300
ABM 80 I-1	300	80	1000	11,0		302

Permissible negative pressure:	0.5 bar
Permissible internal pressure:	10 bar
Permissible medium temperature:	80°C ①

The stated performance data are to be understood only as an outline of performance of our products. For exact limits of application please refer to the quotation and acceptance of order.

① Models for higher temperatures upon request.

② With sludge of 3-8% dry substance throughput is reduced by up to half.

## Materials

Denomination	Part No.	Material W1
Sealing cover	210	GG-20
Complete impeller	403	1.4312 with stellite segments
Pressure ring	408	1.0112
Cutting ring	409	1.2601
Cutting ring bearing	410	acrylonitrile-butadiene rubbers (NBR)

Macerator casing 502 GG-20

## Accessories

The following are supplied at extra cost:

Seal water supply unit for shaft sealing, consisting of dirt catcher, pressure reducer and gauge, solenoid valve, nonreturn valve and complete piping.

Macerator control for seal water unit and the automatic change of the sense of rotation.

Further information can be found on the backside of this brochure and in our brochure VM 770.0001 – Ident-Nr. 151003.

Sectional Drawing

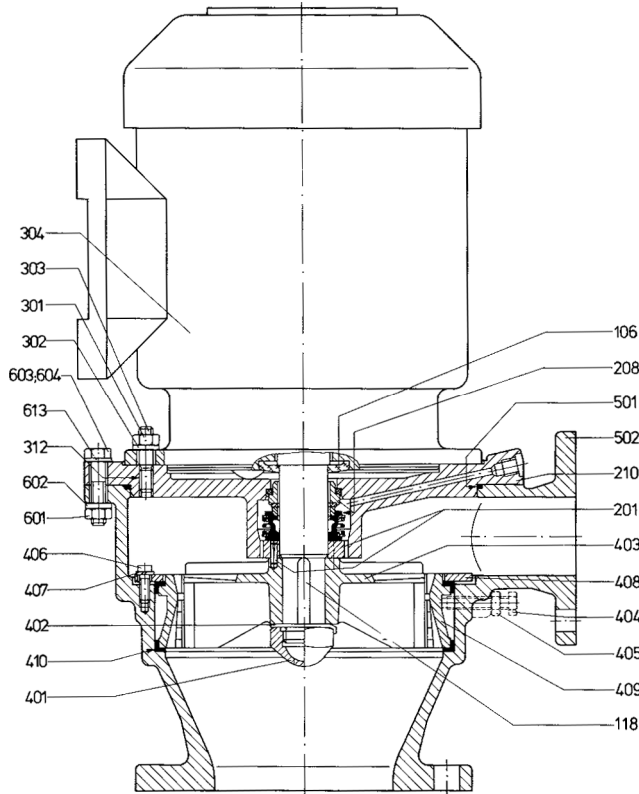

ABM ... S-1 with drive motor

Denomination	Part No.
Splash ring	106
Key	118
Distance ring with grooved pin	201
Mechanical seal	208
Sealing cover	210
Hexagonal nut	301
Serrated lock washer	302
Stud	303
Motor	304
Loctite	312
Shaft nut	401
Locking plate	402
Impeller complete	403 <sup>①</sup>
Hexagonal screw	404
Hexagonal nut	405
Socket head cap screw	406
Spring washer	407
Pressure ring	408
Cutting ring	409
Cutting ring bearing	410
O-ring	501
Macerator casing	502
Hexagonal nut	503 <sup>②</sup>
Serrated lock washer	504 <sup>②</sup>
Hexagonal bolt	505 <sup>②</sup>
Foundation plate	506 <sup>②</sup>
O-ring	507 <sup>②</sup>
Hexagonal nut	508 <sup>②</sup>
Handhole cover	509 <sup>②</sup>
Handhole gasket	510 <sup>②</sup>
Stud	511 <sup>②</sup>
Threaded plug	512 <sup>②</sup>
Joint washer	513 <sup>②</sup>
Hexagonal nut	601
Serrated lock washer	602
Hexagonal bolt	603
Stud	604
Washer	613

<sup>①</sup> Consisting of: impeller with for soldered-in cutting blades which, when worn can be reversed  
<sup>②</sup> only with Type ABM...I-1

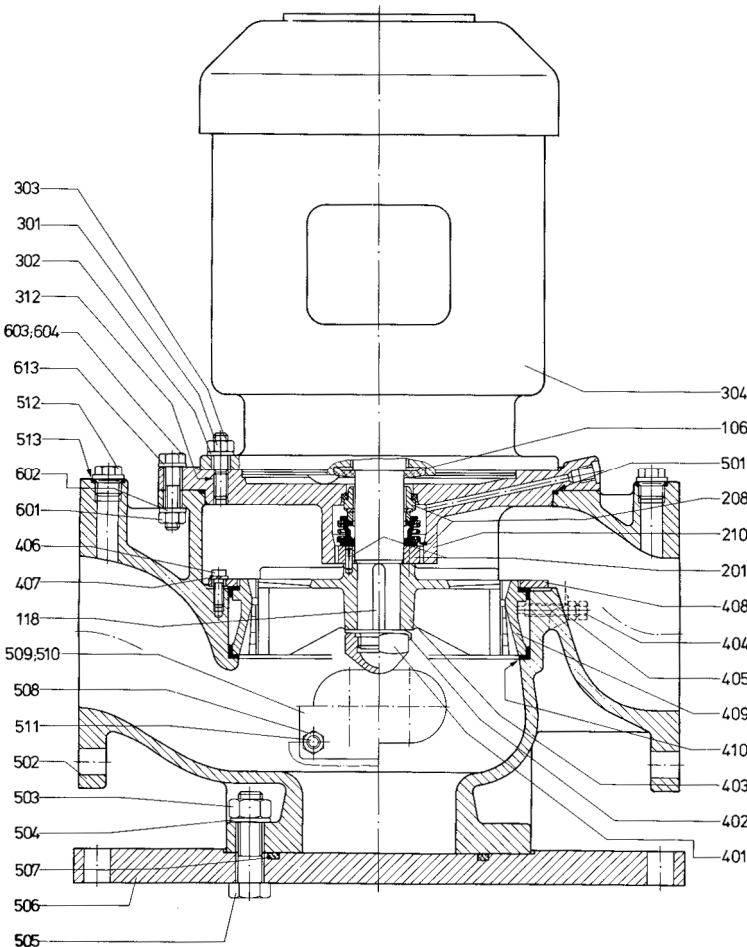

ABM ... I-1 with drive motor

Unit Dimensions  
ABM...S-1

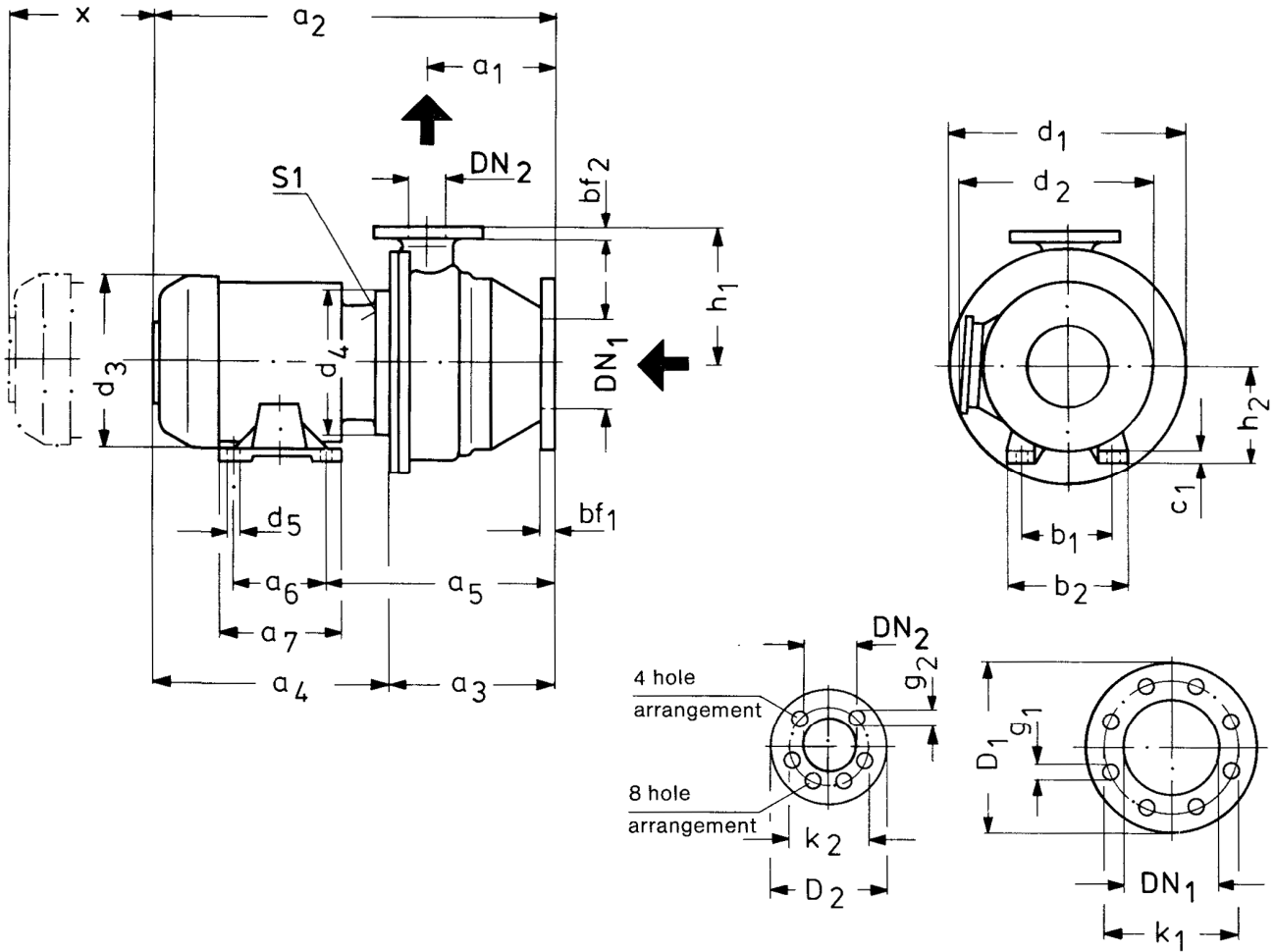

Direction of rotation:  
clockwise and counter-clockwise

Dimensions in mm  
alterations reserved

macerator type	flanges																							
	connection dimensions acc. to DIN 2501, PN 10												connection dimensions acc. to ANSI B 16.1 class 125											
	DN <sub>1</sub>	D <sub>1</sub>	bf <sub>1</sub>	k <sub>1</sub>	g <sub>1</sub>	number of holes	DN <sub>2</sub>	D <sub>2</sub>	bf <sub>2</sub>	k <sub>2</sub>	g <sub>2</sub>	number of holes	DN <sub>1</sub>	D <sub>1</sub>	bf <sub>1</sub>	k <sub>1</sub>	g <sub>1</sub>	number of holes	DN <sub>2</sub>	D <sub>2</sub>	bf <sub>2</sub>	k <sub>2</sub>	g <sub>2</sub>	number of holes
ABM 10 S-1	150	282	26	240	22	8	65	185	20	145	18	4	6"	282	26	241	22	8	2 1/2"	185	20	140	19	4
ABM 20 S-1	150	282	26	240	22	8	65	185	20	145	18	4	6"	282	26	241	22	8	2 1/2"	185	20	140	19	4
ABM 40 S-1	200	343	29	295	22	8	80	196	22	160	18	8	8"	343	29	299	22	8	3"	196	22	152	19	4
ABM 80 S-1	200	343	29	295	22	8	80	196	22	160	18	8	8"	343	29	299	22	8	3"	196	22	152	19	4

macerator type	unit dimensions																	extens. measurement x	external sealing S1
	a <sub>1</sub>	a <sub>2</sub>	a <sub>3</sub>	a <sub>4</sub>	a <sub>5</sub>	a <sub>6</sub>	a <sub>7</sub>	b <sub>1</sub>	b <sub>2</sub>	c <sub>1</sub>	d <sub>1</sub>	d <sub>2</sub>	d <sub>3</sub>	d <sub>4</sub>	d <sub>5</sub>	h <sub>1</sub>	h <sub>2</sub>		
AM 10 S-1	210	677	272	405	361	140	218	216	256	18	370	338	246	300	12	220	132	300	G 1/4
AM 20 S-1	210	677	272	405	361	140	218	216	256	18	370	338	246	300	12	220	132	300	G 1/4
AM 40 S-1	278	864	347	517	455	254	304	254	320	22	500	396	312	350	14	295	160	400	G 1/4
AM 80 S-1	278	864	347	517	455	254	304	254	320	22	500	396	312	350	14	295	160	400	G 1/4



Unit Dimensions  
AM..I-1

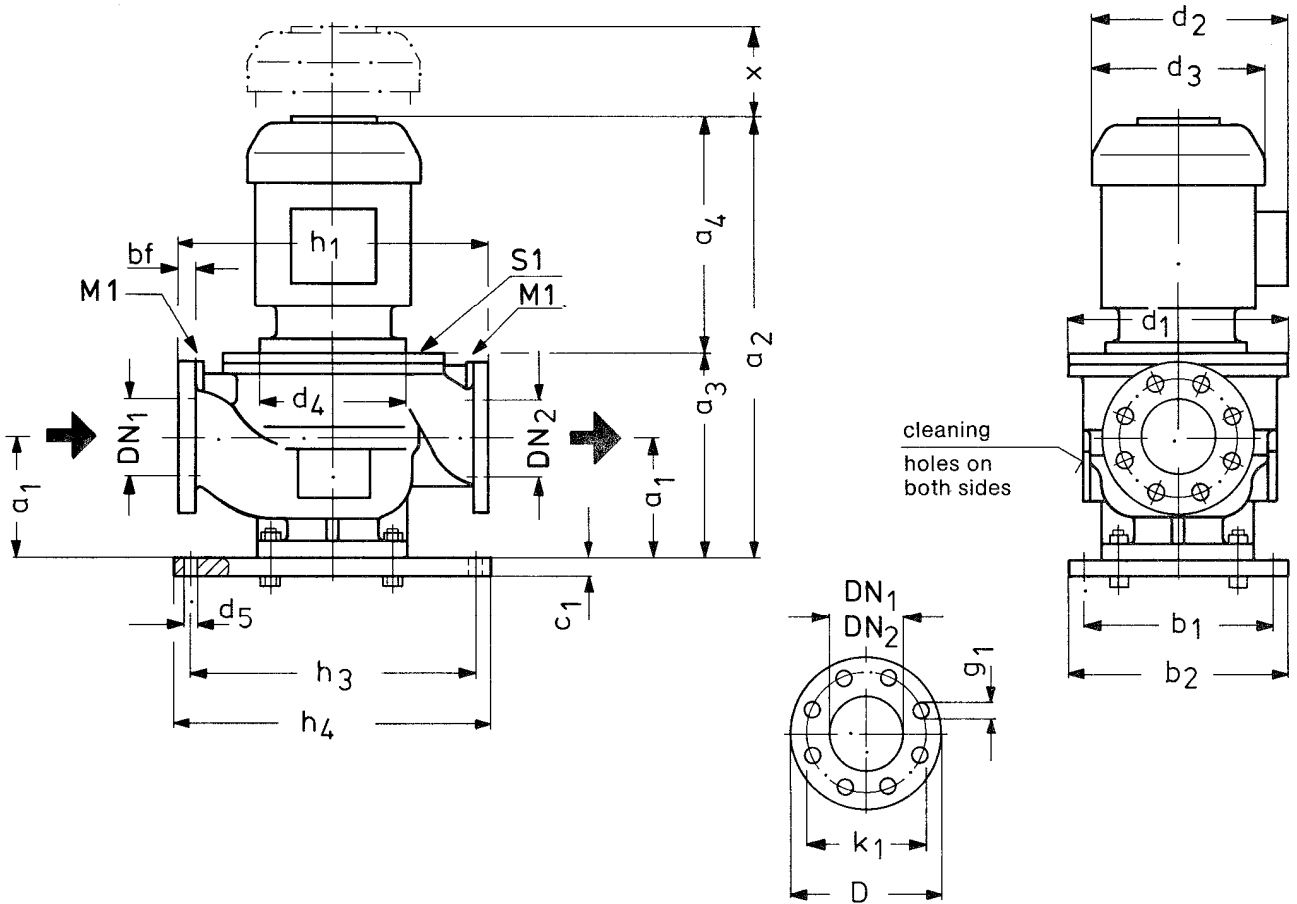

Direction of rotation:  
clockwise and counter-clockwise

Dimensions in mm  
alterations reserved

macerator type	flanges														
	connection dimensions acc. to DIN 2501, PN 10						connection dimensions acc. to ANSI B 16.1 class 125								
	DN <sub>1</sub>	DN <sub>2</sub>	D	bf	k <sub>1</sub>	g <sub>1</sub>	number of holes	DN <sub>1</sub>	DN <sub>2</sub>	D	bf	k <sub>1</sub>	g <sub>1</sub>	number of holes	
AM 10 S-1	125	125	254	26	210	18	8	5"	125	125	254	26	216	22	8
AM 20 S-1	125	125	254	26	210	18	8	5"	125	125	254	26	216	22	8
AM 40 S-1	150	150	285	26	240	22	8	6"	150	150	285	26	241	22	8
AM 80 S-1	150	150	285	26	240	22	8	6"	150	150	285	26	241	22	8

macerator type	unit dimensions															extens. measurement x	connections	
	a <sub>1</sub>	a <sub>2</sub>	a <sub>3</sub>	a <sub>4</sub>	b <sub>1</sub>	b <sub>2</sub>	c <sub>1</sub>	d <sub>1</sub>	d <sub>2</sub>	d <sub>3</sub>	d <sub>4</sub>	d <sub>5</sub>	h <sub>1</sub>	h <sub>3</sub>	h <sub>4</sub>		pressure gauge M1	external sealing S1
ABM 10 I-1	182	722	317	405	310	350	23,5	370	338	246	300	22	500	470	510	300	G 1/2	G 1/4
ABM 20 I-1	182	722	317	405	310	350	23,5	370	338	246	300	22	500	470	510	300	G 1/2	G 1/4
ABM 40 I-1	200	867	350	517	310	350	23,5	500	396	312	350	22	700	470	510	400	G 1/2	G 1/4
ABM 80 I-1	200	867	350	517	310	350	23,5	500	396	312	350	22	700	470	510	400	G 1/2	G 1/4

### Macerator Controller

Function of the controller:

1. Control of the seal water supply unit for the shaft sealing.
2. Automatic change of the sense of rotation with every start in order to increase the service life of the cutting tools or after reaction of the overload protection to prevent clogging.
3. Control of the safety device of a stand-by pump to be put in operation if necessary.

### Functional Characteristic

The macerator control is activated via a start/stop switch. After the release signal (e.g. external pressure or level switch or push button control) the solenoid valve of the seal water unit opens and the mechanical seal is flushed with sealing liquid. After 30 s., macerator and pump are switched on automatically.

After switch-off, macerator and pump stop working immediately while seal water unit shut-off with a delay of 30 s. With every new start, the sense of rotation of the macerator is altered automatically.

To prevent clogging, the macerator control monitors the motor current. When the current limit is exceeded, the contactors are activated and the sense of rotation is changed. If the current remains above the limit, the sense of rotation is changed again. This procedure will be repeated up to 4 times. Is the current still above the limit, macerator and pump will be switched of.

Subject to technical alterations.

**ALLWEILER** 

A Member of the  
COLFAX PUMP GROUP

**ALLWEILER AG - Werk Bottrop**  
**Postfach 200123 · 46223 Bottrop**  
**Kirchhellener Ring 77– 79 · 46244 Bottrop**  
Germany

Tel. +49 (0)2045 966-60

Fax +49 (0)2045 966-679

E-mail: [service-ge@allweiler.de](mailto:service-ge@allweiler.de)

Internet: <http://www.allweiler.com>

VM 601 GB/01.98 – Ident No. 795 891