

Vertical Marine Centrifugal Pumps PN 10 (individual sizes up to PN 25) for pedestal or wall mounting

ALLMARINE Series MI with radial inlet Series MA with axial inlet

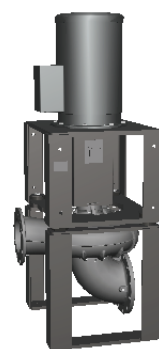

MI-S

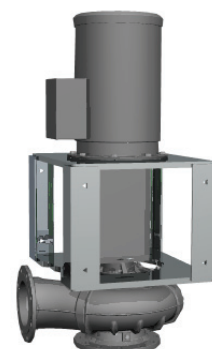

MA-W

Application

For handling fresh water, sea water, condensate, oils.

Main areas of application

In marine engineering: as a general service and fire extinguisher pump; as a bilge, ballast and cooling water pump; and as a sea water pump.

In industry: for general water supply and in cooling and recirculation circuits.

Structural design

Single-stage, single-flow volute-casing centrifugal pump in short, compact design. Volute casing can be supplied optionally with axial or radial intake branch. In the shipbuilding and industry the delivery rate and hydraulics are closely attuned to the needs.

Volute casing and bearing unit are joined to the drive motor via a lantern. Elastically applied feet make the vibration isolated vertical pedestal mounting possible. Side drill holes permit wall mounting. Through the use of an coupling with distance piece the bearing unit an sealing unit, including impeller, can be dismantled without removing the volute casing, the pipes or the drive motor.

As the pump and drive motor are precisely centered in the lantern, no alignment is required.

Performance data

Q	up to	1800	m ³ /h
H	up to	65	m (individual sizes up to 140 m)
t	up to	40	°C (sea water)
	up to	100	°C (fresh washer)
p _d	up to	10	bar (individual sizes up to 25 bar)

The limits quoted are maximums. Figures may be lower depending on specified technical execution. Inlet pressure plus maximum delivery head must not exceed the permissible outlet pressure.

The mentioned performance data are to be considered as a product and performance abstract only. The particular operating limits can be taken from the quotation or order acknowledgement.

Branch positions/Flanges

MI: Suction branch: as seen from the drive side at 180° to the delivery branch (standard).

The intake branch can be arranged 90° to the right and 90° to the left.

MA: Suction branch: axial

Nominal width:	Suction branch	125 up to 400 mm
	Delivery branch	65 up to 350 mm

to DIN EN 1092-2

Contact protection

The requirements of DIN EN 809 "Contact protection", are met.

Shaft sealing

By uncooled, unbalanced, maintenance-free mechanical seal.

Material design

Sliding ring	carbon, antimony-impregnated
Counter-ring	aluminium oxide
Bellows	HNBR
O-ring	HNBR

Variation of materials

Sliding ring	Silicon carbide
Counter-ring	Silicon carbide
Bellows	HNBR
O-ring	HNBR

Bearing/Lubrication

Pump side: Lifetime greased groove ball bearing to DIN 625 in casing cover.

Drive side: By bearing of drive motor.

Drive

Surface-cooled three-phase squirrel-cage induction motors, IM V1 type of construction, enclosure IP55 according to IEC Standard, class F insulation, performances and main dimensions according to DIN 42 677.

Abbreviation system

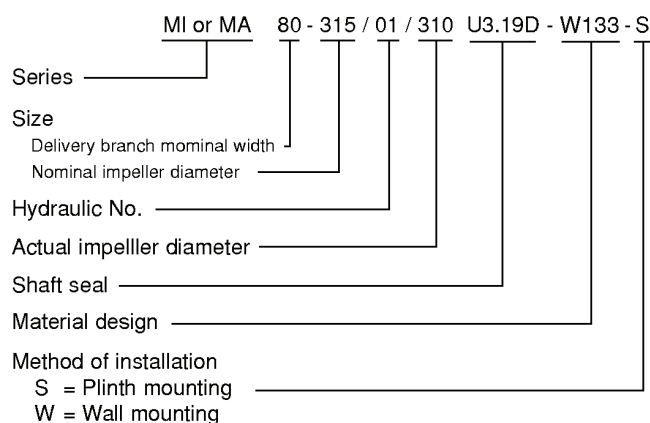

This abbreviation is placed on the name plate.

Materials

Denomination	Part No.	Material designs		
		W133	W134	W135
Volute casing	102.01	G-CuAl10Ni	EN-GJS-400-15 (GGG-40)	
Casing cover	161.01	G-CuAl10Ni	EN-GJS-400-15 (GGG-40)	
Shaft	210.01		1.4462/1.7139 ②	
Impeller	230.01		G-CuAl10Ni	EN-GJL-200 (GG-20)
Lantern	341.01		steel welded	
Wear ring ①	502.01		GC/GZ-CuSn12	
Screws and nuts in contact with fluid			stainless steel	

① Wear rings against surcharge.

② On pump side (in contact with fluid) in 1.4462/on motor side in 1.7139.

Performance graphs

n = 1450 1/min

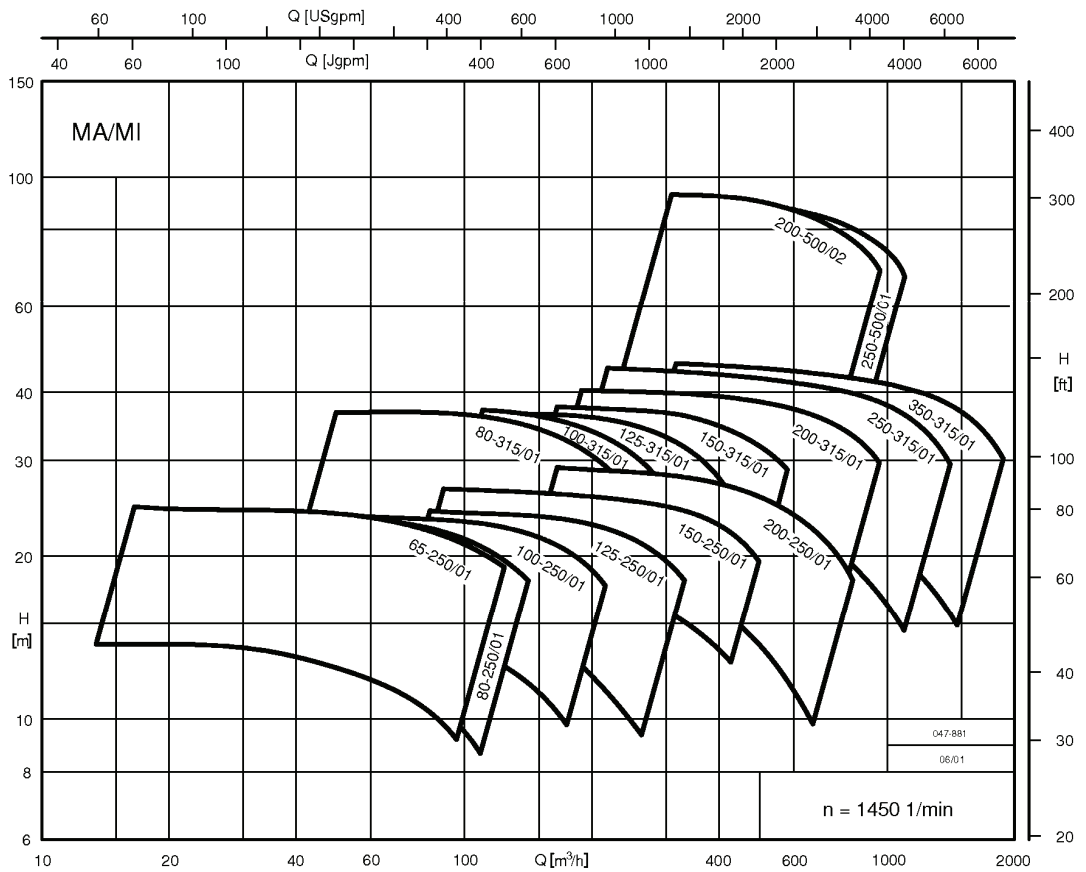

n = 1750 1/min

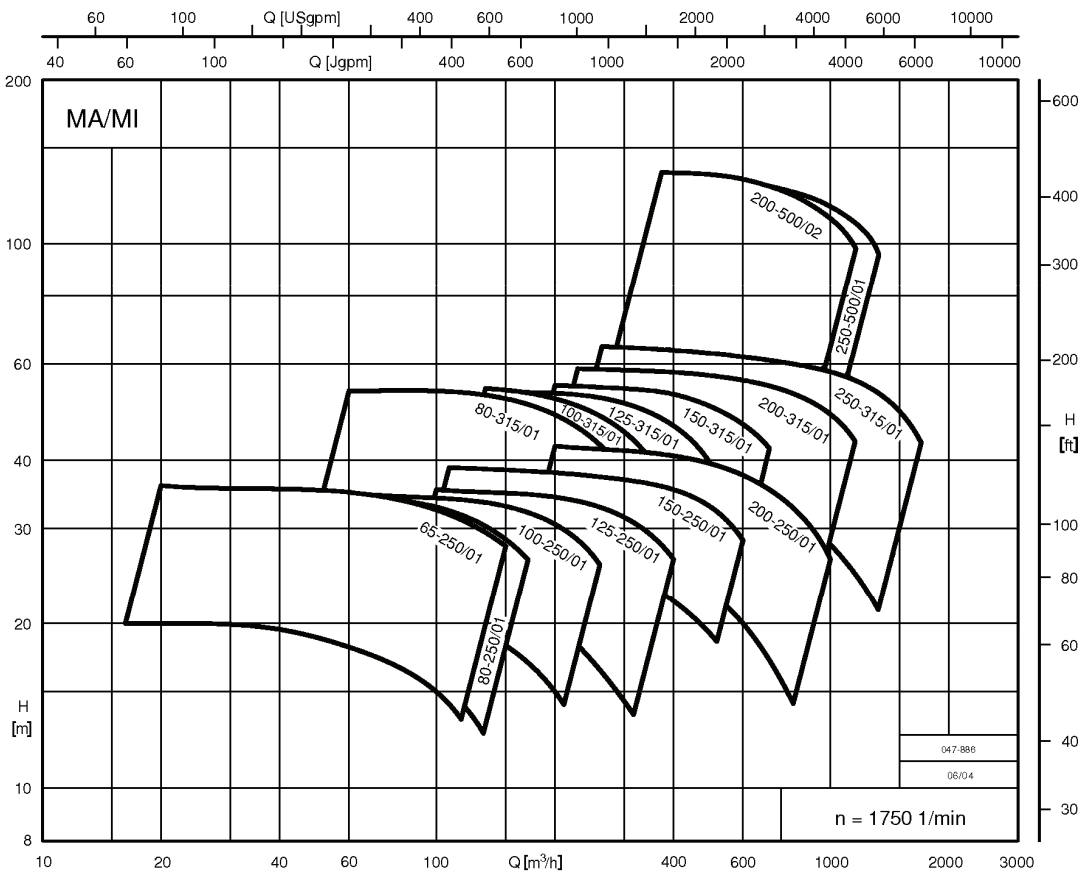

For exact performance data please refer to the individual characteristics.

Sectional drawing
Series MI for pedestal mounting

Wear ring stationary - designs

Volute casing

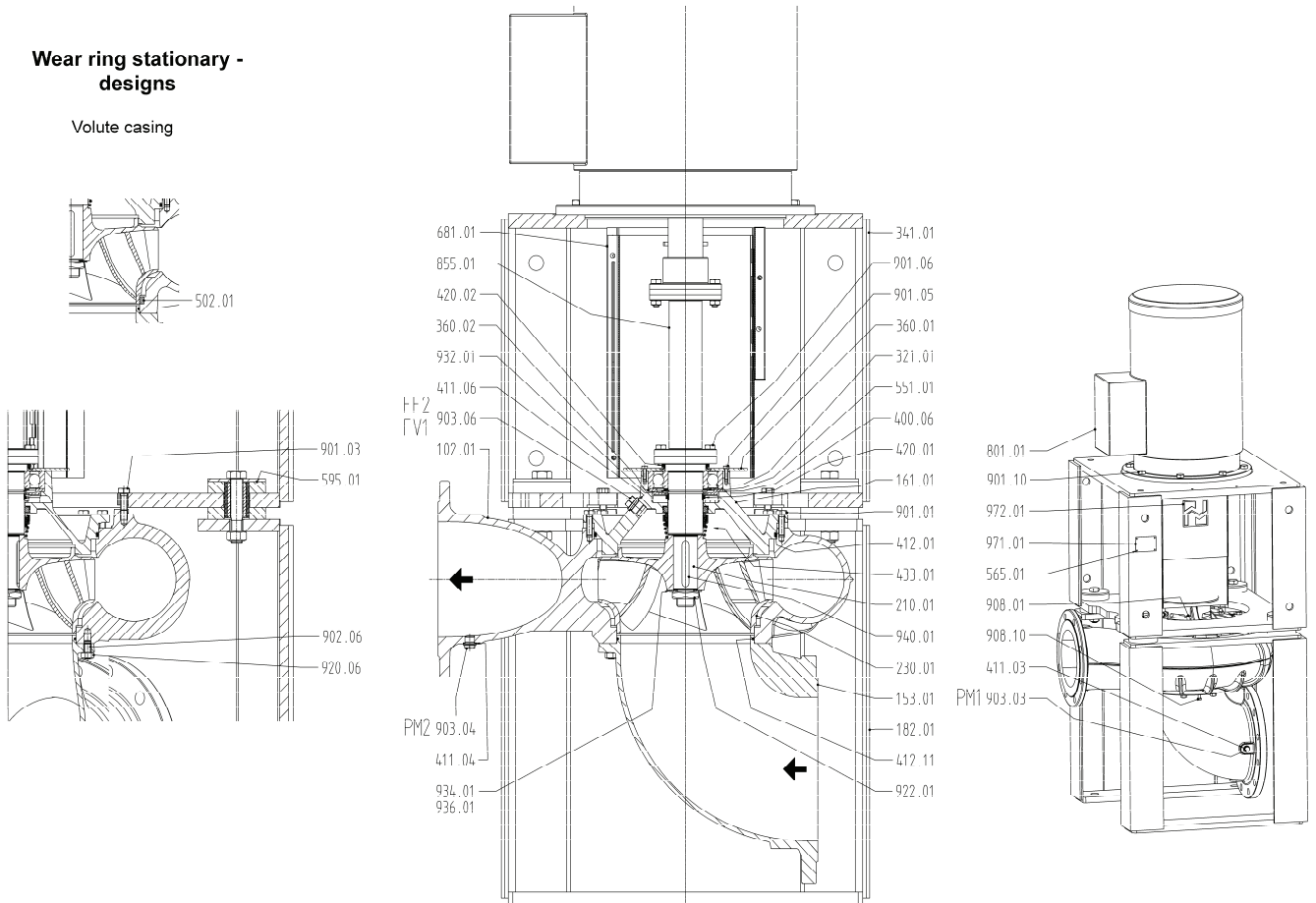

Denomination	Part No.	Denomination	Part No.	Denomination	Part No.
Volute casing	102.01	Wear ring stationary	502.01	Impeller nut	922.01
Suction branch	153.01	Spacer disc	551.01	Circlip	932.01
Casing cover	161.01	Rivet	565.01	Spring disc	934.01
Foot	182.01	Buffer	595.01	Spring ring	936.01
Shaft	210.01	Coupling guard	681.01	Key	940.01
Impeller	230.01	Flange motor	801.01	Name plate	971.01
Radial ball bearing	321.01	Coupling with distance piece	855.01	Information plate	972.01
Motor stool	341.01	Hexagon head screw	901.01		
Bearing cover	360.01	Hexagon head screw	901.03		
Bearing cover	360.02	Hexagon head screw	901.05		
Gasket	400.06	Hexagon head screw	901.06		
Seal ring	411.03	Hexagon head screw	901.10		
Seal ring	411.04	Stud	902.06		
Seal ring	411.06	Screw plug	903.03		
O-ring	412.01	Screw plug	903.04	Connections	
O-ring	412.11	Screw plug	903.06	FF2 Filling	
Shaft seal ring	420.01	Jack screw	908.01	FV1 Venting	
Shaft seal ring	420.02	Jack screw	908.10	PM1 Pressure measurement	
Mechanical seal	433.01	Nut	920.06	PM2 Pressure measurement	

Sectional drawing
Series MA for pedestal mounting

Wear ring stationary - designs

Volute casing

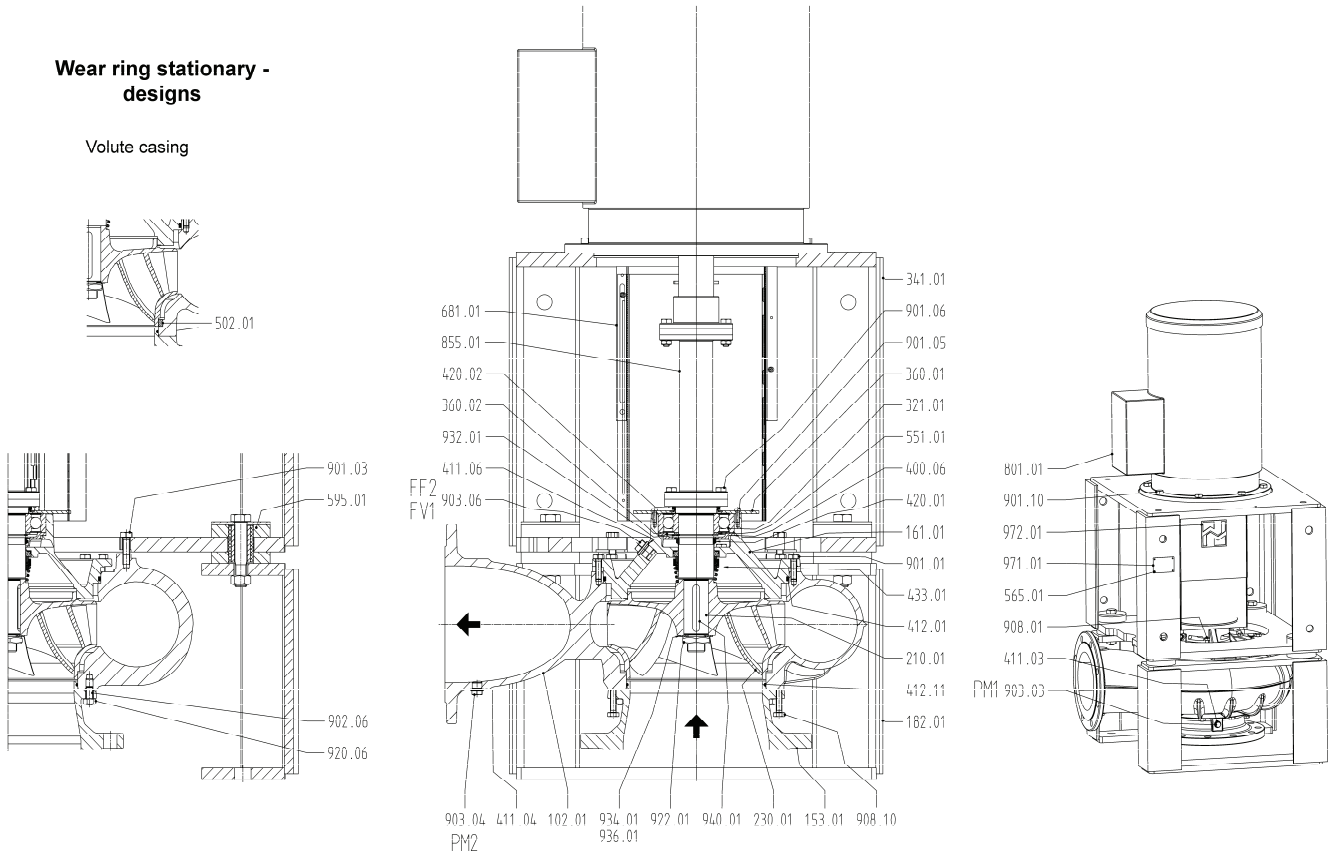

Denomination	Part No.	Denomination	Part No.	Denomination	Part No.
Volute casing	102.01	Wear ring stationary	502.01	Impeller nut	922.01
Suction branch	153.01	Spacer disc	551.01	Circlip	932.01
Casing cover	161.01	Rivet	565.01	Spring disc	934.01
Foot	182.01	Buffer	595.01	Spring ring	936.01
Shaft	210.01	Coupling guard	681.01	Key	940.01
Impeller	230.01	Flange motor	801.01	Name plate	971.01
Radial ball bearing	321.01	Coupling with distance piece	855.01	Information plate	972.01
Motor stool	341.01	Hexagon head screw	901.01		
Bearing cover	360.01	Hexagon head screw	901.03		
Bearing cover	360.02	Hexagon head screw	901.05		
Gasket	400.06	Hexagon head screw	901.06		
Seal ring	411.03	Hexagon head screw	901.10		
Seal ring	411.04	Stud	902.06		
Seal ring	411.06	Screw plug	903.03		
O-ring	412.01	Screw plug	903.04		
O-ring	412.11	Screw plug	903.06		
Shaft seal ring	420.01	Jack screw	908.01		
Shaft seal ring	420.02	Jack screw	908.10		
Mechanical seal	433.01	Nut	920.06		
				Connections	
				FF2 Filling	
				FV1 Venting	
				PM1 Pressure measurement	
				PM2 Pressure measurement	

Unit dimensions – series MI for pedestal mounting

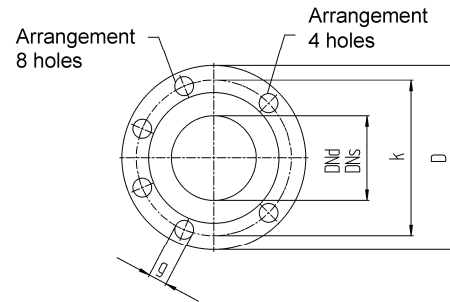
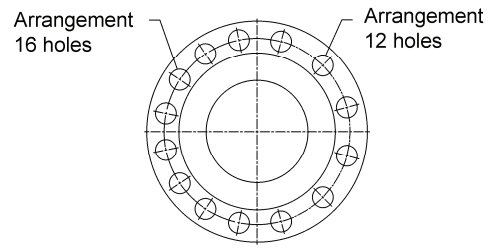
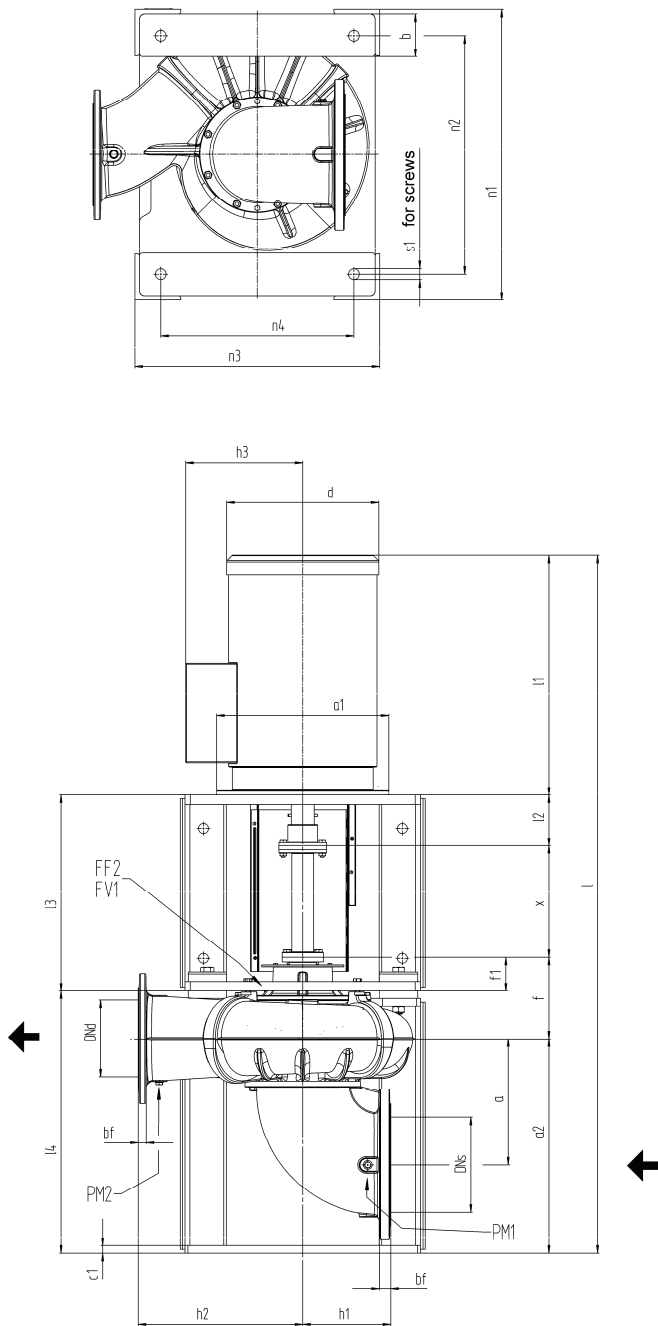

Sense of rotation: Clockwise seen from drive side.
Dimensions in mm. Subject to alterations.

Flanges acc. to EN 1092-2 PN 10

DN _s / DN _d	D	bf	k	g	No. of holes
65	185	19	145	19	4
80	200	19	160	19	8
100	220	19	180	19	8
125	250	19	210	19	8
150	285	19	240	23	8
200	340	20	295	23	8
250	395	22	350	23	12
300	445	24,5	400	23	12
350	505	24,5	460	23	16
400	565	24,5	515	28	16

Flanges acc. to EN 1092-2 PN 16

DN _s / DN _d	D	bf	k	g	No. of holes
200	340	20	295	23	12
250	405	22	355	28	12

Flanges acc. to EN 1092-2 PN 16

DN _s / DN _d	D	bf	k	g	No. of holes
250	425	24,5	370	31	12
300	485	27,5	430	31	16

Connections

Filling	Venting	Pressure measurement
FF2	FV1	PM1 / PM2
G 1/2	G 1/2	G 3/8

Unit dimensions – series MI for pedestal design

Sense of rotation: Clockwise seen from drive side.
Dimensions in mm. Subject to alterations.

Size			Unit dimensions																															
Pump	Housing cover	Motor	Pump dimensions									Dismantling dimension x	Foot dimensions							Total length approx. l														
			DN _s	DN _d	a	a2	f	f1	h1	h2	h3		b	c1	l4	n1	n2	n3	n4		s1													
65-250/01	250/40	132S/M	125	65	210	410	165,5	98,5	150	250	416	230	90	20	477	500	395	480	375	M20	1267													
		160M/L ③									446										1401													
132S/M		150	80	235	407	168,1	416		175	250	416										1267													
160M/L ③							446				1401																							
100-250/01	250/50	160M/L	150	100	250	486	108,2	175	275	456	270		90	20	574	600	490	560	450	M24	1509													
180M/L		1509																																
160M/L		200	125	290	483	199,9		200	275	486											1633													
180M/L																					1633													
125-250/01	315/50	200L ③	200	100	275	497	185,9	200	315	486			270	90	20	574	600	490	560	450	M24	1690												
		225S/M ③																				1727												
160M/L		150	80	235	500	182,7		175	315	456												1508												
180M/L																						1632												
80-315/01	250/60	200L	200	100	275	497	185,9	200	315	486				270	90	20	574	600	490	560	450	M24	1690											
		225S/M ③																					1722											
180M/L		200	150	305	570	220,5		210	350	487													1780											
200L																							1838											
150-250/01	315/60	225S/M	250	200	330	563	227,6	230	430	517					270	110	20	691	760	625	640	505	M24	1875										
		250M ③										1998																						
200L		250	200	330	563	227,6		230	430	517		1838																						
225S/M												1875																						
200-250/01	315/60	250M	250	200	330	563	227,6	230	430	517		270				110	20	691	760	625	640	505	M24	1998										
		280S/M ③									2073																							
315S/M ③		2208																																
200L		200	125	275	575	215,7		200	350	517	1838																							
225S/M	1875																																	
125-315/01	315/70	250M ③	250	150	340	571	219,1	220	355	517	270		110			20	691	760	625	640	505	M24	1998											
		280S/M ③																					2073											
200L		250	200	365	690	263,3		113,3	250	440													581	320	150	25	840	900	720	820	640	M30	2208	
225S/M																																	2211	
250M	2286																																	
315S/M ③	2421																																	
250-315/01	315/80	315S/M	300	250	390	682	271,8	280	530	611			320	150		25	840	900	720	820	640	M30	2421											
280S/M ③		2421																																
350-315/01		315S/M	400	350	595	920		272,3	70,3	400					580								648		320	150	25	1122	1080	900	960	780	M30	2740
200-500/02 ①		280S/M																																250
250-500/01 ②	315S/M	2418																																
315S/M	300	250	410	690	260,4	110,4	275	700	608	320				150	25	840	900	720	820	640	M30	2418												
200-315/01												225S/M										2088												

① Flange acc. to EN 1092-2 PN 16 ② Flange acc. to EN 1092-2 PN 25
 ③ Attention! With these motor sizes the terminal box dimension h3 is bigger than pump dimension h2.

The stated dimensions are approximate.
 Exact data dependant on motor brand.
 At drive performances over 132 kW consultation is necessary due to non standardized motor connections.

On use of special ship motors, precautions must be taken towards different pump sizes depending on protection type with according performances.
 The main dimensions change accordingly.

Motor dimensions

Speed	Size	Performance	Motor dimensions				
			Flange diameter	Outside diameter	Terminal box	Shaft end	Length
1/min	Motor	kW	a1	d	h3	d2 x l2	l1
1750 1450 1180	132S/M	5,5/7,5	300	270	233	38 x 80	374
	160M/L	11/15	350	310	257	42 x 110	478
	180M/L	22	350	375	275	48 x 110	602
	200L	30	400	415	310	55 x 110	660
	225S/M	37/45	450	470	339	60 x 140	667
	250M	55	550	520	430	65 x 140	790
	280S/M	75/90	550	575	455	75 x 140	865
	315S/M	110/132	660	645	515	80 x 170	970

Unit dimensions – supplementary dimensions for wall mounting

Series MI

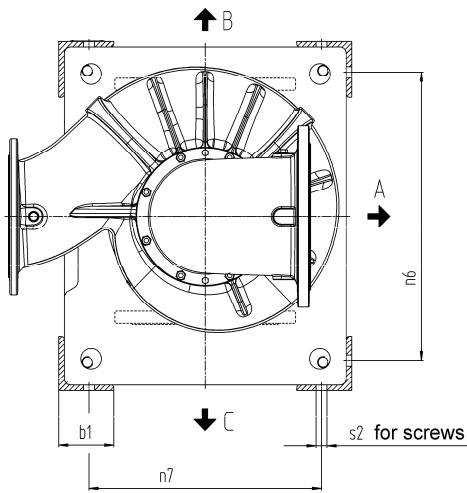

Series MA

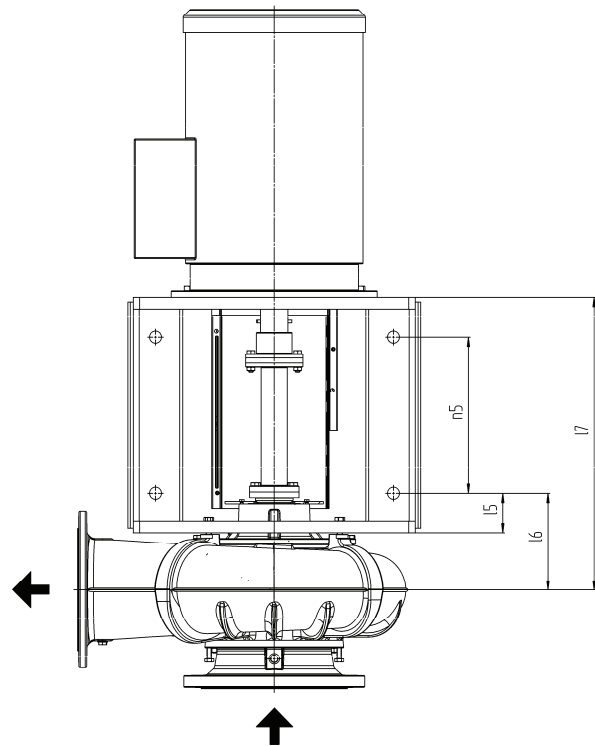
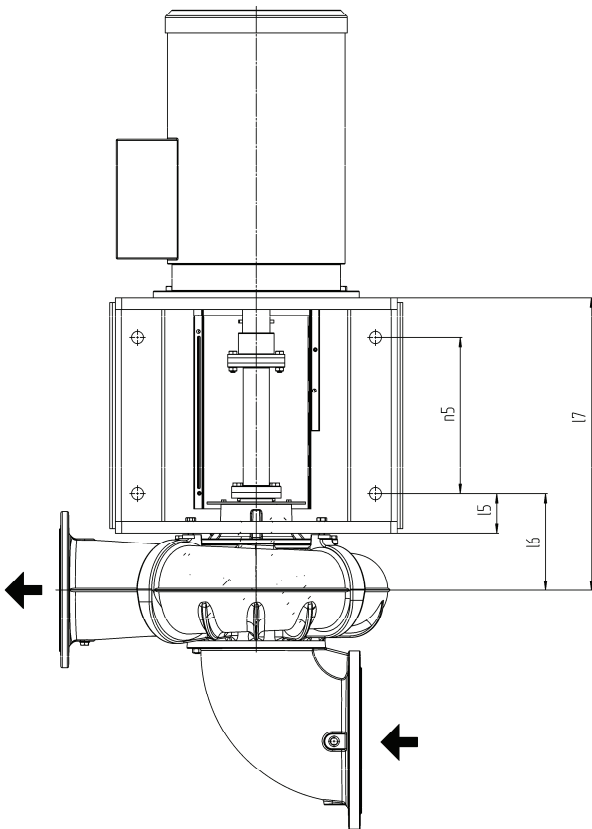
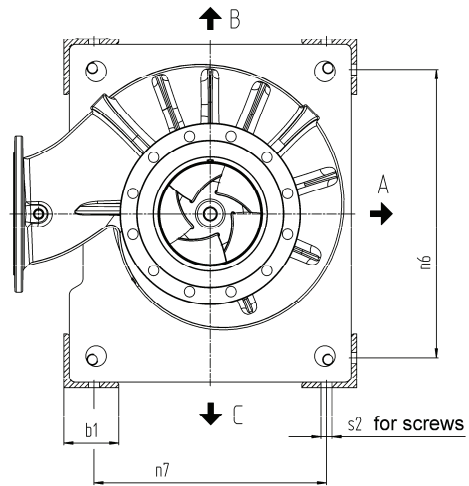

Sense of rotation: Clockwise seen from drive side.
Dimensions in mm. Subject to alterations.

Series	Possible variations for wall mounting			Possible suction branch positions		
	seen from drive side					
	A	B	C	A	B	C
MI	x	x	x	x	x	x
MA	x	x	x	-	-	-

Unit dimensions – supplementary dimensions for wall mounting, series MI and MA

Sense of rotation: Clockwise seen from drive side.
Dimensions in mm. Subject to alterations.

Size			Dimensions for wall mounting								
Pump	Housing cover	Motor	b1	l5	l6	l7	n5	n6	n7	s2	
65-250/01	250/40	132S/M	90	80	143	483	260	400	380	M20	
		160M/L				513	290				
80-250/01		132S/M			145,6	485,6	260				
		160M/L				515,6	290				
		180M/L									
100-250/01		250/50			160M/L	100	80				164,4
180M/L											
125-250/01	160M/L		167,2	547,2							
	180M/L			577,2	320						
	200L										
225S/M											
80-315/01	315/50	160M/L	100	80	150	530	290	490	450	M24	
		180M/L									
		200L									
100-315/01		180M/L			153,2	533,2					
		200L				563,2	320				
		225S/M									
150-250/01	250/60	180M/L	120	80	197	518	320	630	510	M24	
		200L									
		225S/M									
		250M									
200-250/01		200L			204,1	615,1	350				
		225S/M				645,1					
		250M				675,1	380				
		280S/M				603,2	320				
315S/M											
125-315/01	315/60	200L	192,2	633,2	350	630	510	570			
		225S/M									
		250M									
		280S/M									
150-315/01		200L	195,6	606,6	350						
		225S/M		636,6							
		250M		666,6				380			
		280S/M									
315S/M											
200-315/01	315/70	225S/M	160	100	246	729	380	730	650	M30	
		250M									
		280S/M									
		315S/M			759	410					
250-315/01		254,5	769,5								
350-315/01	315/80	315S/M	120	318	850	410	910	790	M30		
200-500/02	500/80	280S/M	100	100	236	718	380	730	650	M30	
		315S/M				748	410				
		315S/M			246	758					

Unit dimensions – series MA for pedestal mounting

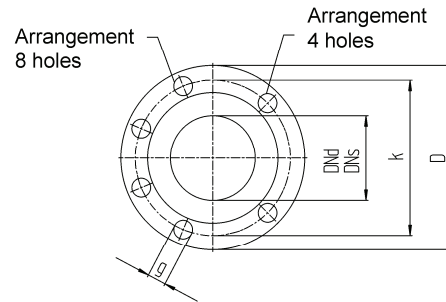
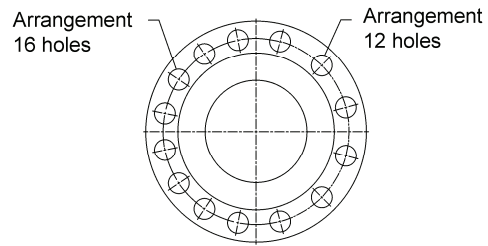
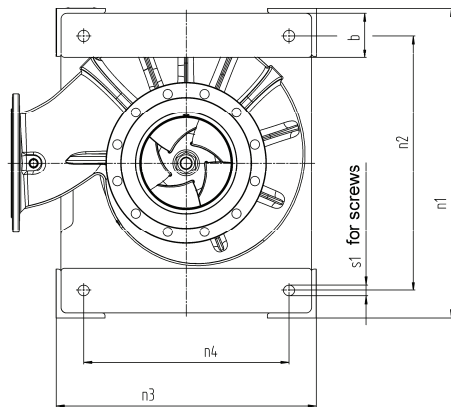

Sense of rotation: Clockwise seen from drive side.
Dimensions in mm. Subject to alterations.

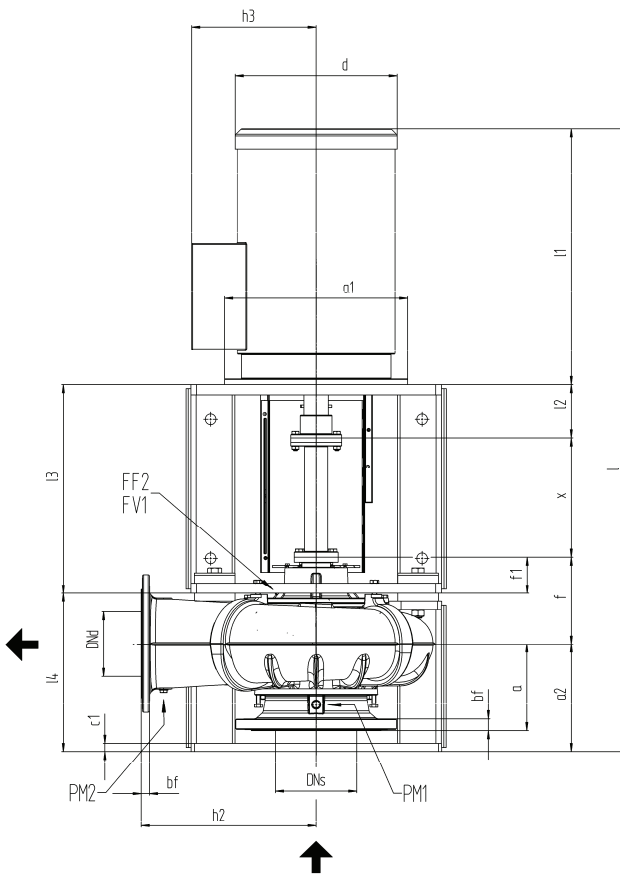

Flanges acc. to EN 1092-2 PN 10

DN _s / DN _d	D	bf	k	g	No. of holes
65	185	19	145	19	4
80	200	19	160	19	8
100	220	19	180	19	8
125	250	19	210	19	8
150	285	19	240	23	8
200	340	20	295	23	8
250	395	22	350	23	12
300	445	24,5	400	23	12
350	505	24,5	460	23	16
400	565	24,5	515	28	16

Flanges acc. EN 1092-2 PN 16

DN _s / DN _d	D	bf	k	g	No. of holes
200	340	20	295	23	12
250	405	22	355	28	12

Flanges acc. EN 1092-2 PN 25

DN _s / DN _d	D	bf	k	g	No. of holes
250	425	24,5	370	31	12
300	485	27,5	430	31	16

Connections

Filling	Venting	Pressure measurement
FF2	FV1	PM1 / PM2
G 1/2	G 1/2	G 3/8

Unit dimensions – series MA for pedestal design

Sense of rotation: Clockwise seen from drive side.
Dimensions in mm. Subject to alterations.

Size			Unit dimensions																									
Pump	Housing cover	Motor	Pump dimensions									Dismantling dimension x	Foot dimensions							Total length approx. l								
			DN _s	DN _d	a	a2	f	f1	h2	l3	b		c1	l4	n1	n2	n3	n4	s1									
65-250/01	250/40	132S/M	125	65	150	230	165,5	98,5	250	416	230	90	20	297	500	395	480	375	M20	1087								
		160M/L ③								446										1221								
132S/M		150	80	175	227	168,1	250		416	1087																		
160M/L ③									446	1221																		
80-250/01	180M/L ③								446										1345									
100-250/01	250/50	160M/L	150	100	190	266	108,2	275	456	230	90	20	354	600	490	560	450	M24	1289									
180M/L																										1413		
160M/L		200	125	210	263	199,9		275	486										230	90	20	354	600	490	560	450	M24	1288
180M/L																												
125-250/01	200L ③																		1470									
	225S/M ③																		1507									
80-315/01	315/50	160M/L	150	80	175	280	108,2	315	456	230	90	20	354	600	490	560	450	M24	1288									
		180M/L																									1412	
		200L																			1470							
100-315/01		180M/L	200	100	200	277		185,9	315										486	230	90	20	354	600	490	560	450	M24
	200L															1488												
	225S/M ③																		1507									
150-250/01	250/60	180M/L	200	150	220	270	99,5	350	487	270	110	20	391	760	625	700	565	M24	1480									
		200L																									1538	
		225S/M																			1575							
		250M ③																			1698							
	200L	250	200	215	263	227,6	99,5	430	517	270	110	20	391	760	625	700	565	M24	1538									
	225S/M																										1715	
	250M																										1698	
	280S/M ③																										1773	
	315S/M ③									1908																		
125-315/01	315/60	200L	200	125	220	275	99,5	350	487	270	110	20	391	760	625	700	565	M24	1538									
		225S/M																									1575	
		250M ③																			1698							
		280S/M ③																			1773							
	200L	250	150	230	271	219,1	99,5	355	517	270	110	20	391	760	625	700	565	M24	1538									
	225S/M																										1575	
	250M ③																										1698	
	280S/M ③																										1773	
	315S/M ③									1908																		
150-315/01	200L																		1538									
	225S/M																		1575									
	250M ③																		1698									
	280S/M ③																		1773									
	315S/M ③																		1908									
200-315/01	315/70	225S/M	250	200	240	340	113,3	440	581	320	150	25	490	900	720	820	640	M30	1738									
		250M																									1861	
		280S/M ③																			1936							
		315S/M ③																			2071							
250-315/01	315S/M	300	250	240	332	271,8		530	611										2071									
350-315/01	315S/M	400	350	320	380	272,3	70,3	580	648	400	150	25	582	1080	900	960	780	M30	2200									
200-500/02 ①	500/80	280S/M	250	200	225	350	250,4	110,4	625	578	320	150	25	490	900	720	820	640	M30	1933								
		315S/M																										2068
250-500/01 ②		315S/M	300	250	275	340	260,4		700	608	320	150	25	490	900	720	820	640	M30	2068								

① Flange acc. to EN 1092-2 PN 16

② Flange acc. to EN 1092-2 PN 25

③ Attention! With these motor sizes the terminal box dimension h3 is bigger than pump dimension h2.

The stated dimensions are approximate.

Exact data dependant on motor brand.

At drive performances over 132 kW consultation is necessary due to non standardized motor connections.

On use of special ship motors, precautions must be taken towards different pump sizes depending on protection type with according performances.

The main dimensions change accordingly.

Motor dimensions

Speed 1/min	Size Motor	Capacity kW	Motor dimensions					
			Flange diameter		Outside diameter	Terminal box	Shaft end	Length
			a1		d	h3	d2 x l2	l1
1750 1450 1180	132S/M	5,5/7,5	300		270	233	38 x 80	374
	160M/L	11/15	350		310	257	42 x 110	478
	180M/L	22	350		375	275	48 x 110	602
	200L	30	400		415	310	55 x 110	660
	225S/M	37/45	450		470	339	60 x 140	667
	250M	55	550		520	430	65 x 140	790
	280S/M	75/90	550		575	455	75 x 140	865
	315S/M	110/132	660		645	515	80 x 170	970

Technische Änderungen bleiben vorbehalten.

ALLWEILER 
A Colfax Business Unit

ALLWEILER AG
Postfach 1140 • 78301 Radolfzell
Allweilerstr. 1 • 78315 Radolfzell
Germany
Tel. +49 (0)7732 86-0
Fax. + 49 (0)7732 86-436
E-Mail: service@allweiler.de
Internet: <http://www.allweiler.com>
VM 846 GB/09.06 – Ident-No. 796 140