

Volute Casing Centrifugal Pumps PN 16 for the purpose of fire-fighting



ALLMARINE[®]

Series NAM-F with axial inlet for pedestal mounting or wall mounting

Application

For handling fresh and sea water. The liquids to be pumped must not contain any abrasive particles.

Main field of application

In shipbuilding as fire-fighting pump.

Design

Single-stage, single-flow volute casing centrifugal pump. Volute casing with axial inlet and radial outlet. Nominal capacities according to DIN EN 22 858 or DIN EN 733.

Pump casing and bearing unit are connected with the driving motor by means of a pump bracket. Feet at the lower flange of the pump bracket allow vertical pedestal mounting. Laterally arranged consoles permit vertical wall mounting.

General application of spacer couplings allows dismantling of the bearing unit including impeller without removing the volute casing, pipelines or driving motor. Aligning of the coupling is not necessary as the pump and driving motor are exactly centered in the pump bracket, i.e. intermediate ring.

All screw connections are by means of hexagonal head bolts and hexagonal nuts so that even after repeated painting (ship-building), proper loosening of same will be caused.

Performance data

Capacity	Q	up to	440 m ³ /h
Delivery head	H	80 up to	145 m
Temperature	t	up to	90 °C
Inlet pressure	p _s	①	
Outlet pressure	p _d	up to	16 bar

① Inlet pressure plus max. delivery head must not exceed the admissible outlet pressure.

Branch position and flanges

Suction branch: axial
Delivery branch: radial
Flanges: according to DIN EN 1092-2 PN 16

Shaft coupling and safety guarding

Flexible shaft coupling with spacer (spacer coupling) and safety guarding according to DIN EN 294.

Shaft sealing

By normed, maintenance-free mechanical seal in unbalanced design.

Mechanical seal materials

Rotating ring: hard carbon
Stationary ring: oxide ceramics
O-rings: FPM
Metal parts: stainless steel

Bearing and lubrication

Two grease-lubricated for lifetime groove ball bearings in the bearing bracket as per DIN 625.

Note: Nominal service life of bearing designed for 1000 hours operation at least.

Combination of structural components

The modular system allows reduced stockkeeping of spare parts. For this series, only two bearing units (shaft sizes) are required, each of them with one mechanical seal size. The table on page 2 shows the combination possibilities of structural components of all NAM-F sizes.

Drive

Standard by means of a three-phase motor, type of construction V1.

Connections

FF ② Filling
LO Leakage outlet
FV Venting
PM1 Pressure gauge
PM2 Pressure gauge

② only size 65-250/01 and 80-250/01, see also automatic aspirator page 10

Abbreviation

The structure of the abbreviation of a NAM-F pump

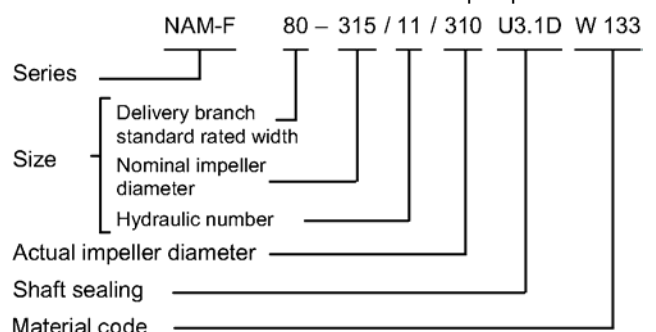

This abbreviation is entered on the nameplate.

Materials

Denomination	Part No.	Material code
		W 133
Volute casing	102...	CC333G
Casing cover	161...	CC333G
Shaft	210...	1.4462
Impeller	230...	CC333G
Bearing bracket	330...	EN-GJL-250
Pump bracket	346...	steel welded
Screws and nuts coming into contact with the liquid to be pumped	-	stainless steel

Combination of structural components

The table below shows the combination possibilities of structural components and parts of sizes NAM-F.

Within a vertical column, parts with identical numbers are interchangeable.

Bearing bracket size	Pump size	Bearing bracket	Shaft	Casing cover	Mechanical seal Ø	Volute casing	Impeller	Pump bracket	Pump foot	Console (for wall mounting)	Coupling guard	Spacer ring (under coupling guard)
470	65-250/01	1	1	1	40	1	1	1	1	1	1	1
	80-250/01					2	2					
530	65-315/11	2	2	3	50	3	3	2	2	2	2	-
	80-315/11					4	4					
	100-250/11			2		5						
	100-315/11			3		6						
	125-250/11			2		7						
	125-315/11			3		8						

Standard motor for using in the marine

Process design
Due to the spacer element it is possible to remove the insert unit without dismantling the motor or the volute casing.

Simple alignment due to the one-piece bearing housing

Bearings especially guarded through the V-ring

Uncooled, **maintenance free mechanical seal** with self flushing

Top quality materials, sea water resistant and long-living

Vertical installation
Pedestal or wall mounting

Negligible axial thrust by fine adaption of the relief bore

Negligible radial forces at big sizes due to the double volute

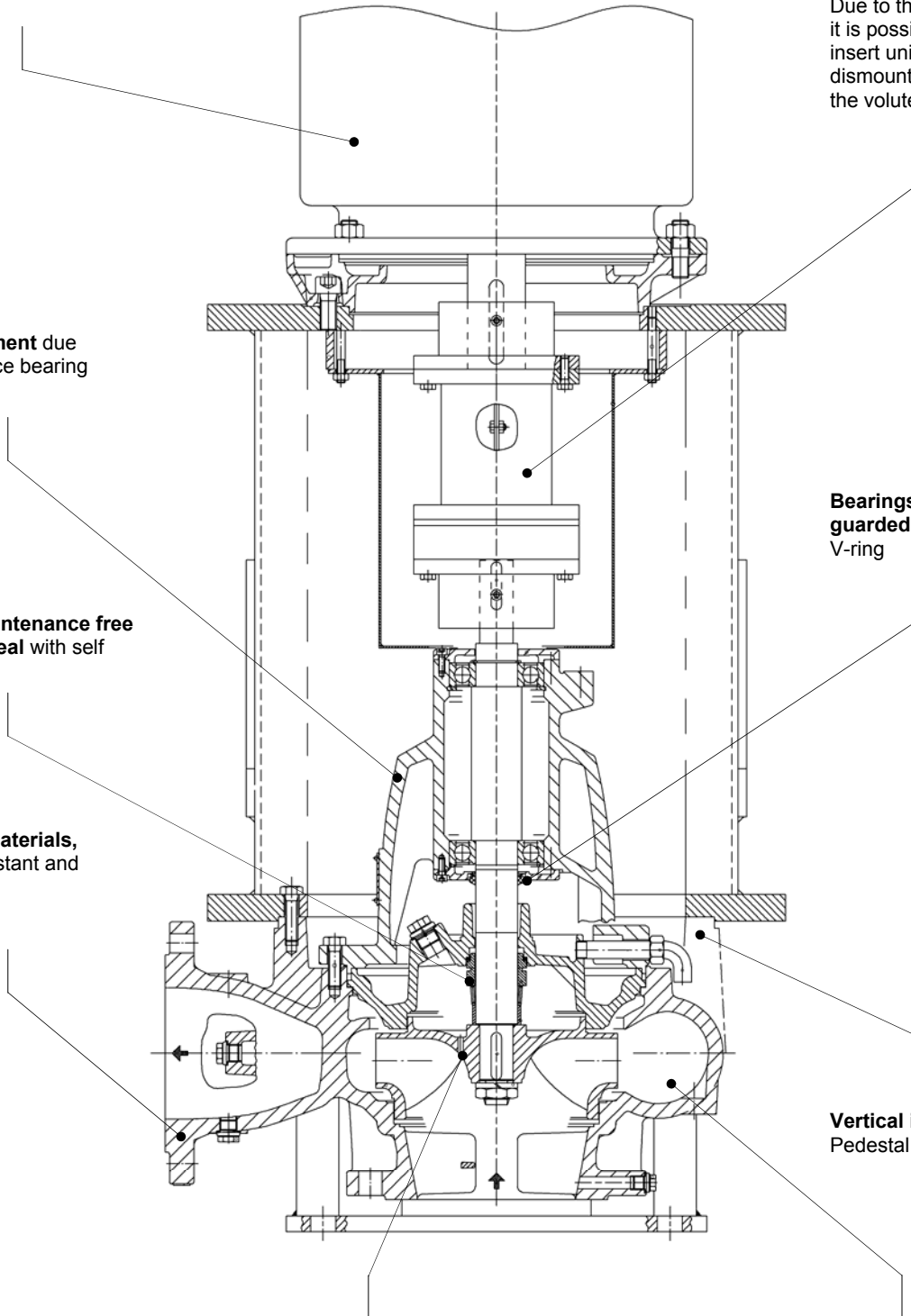

Performance graphs

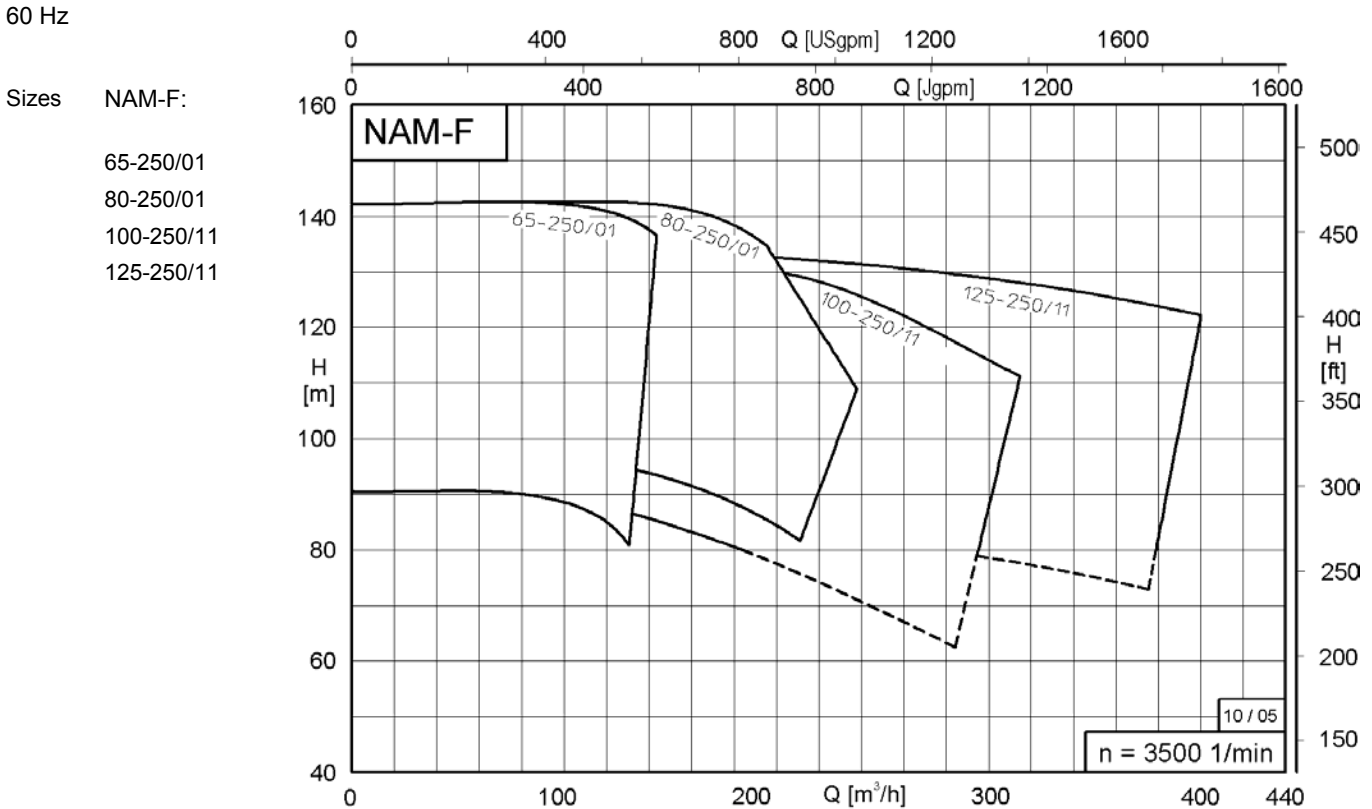
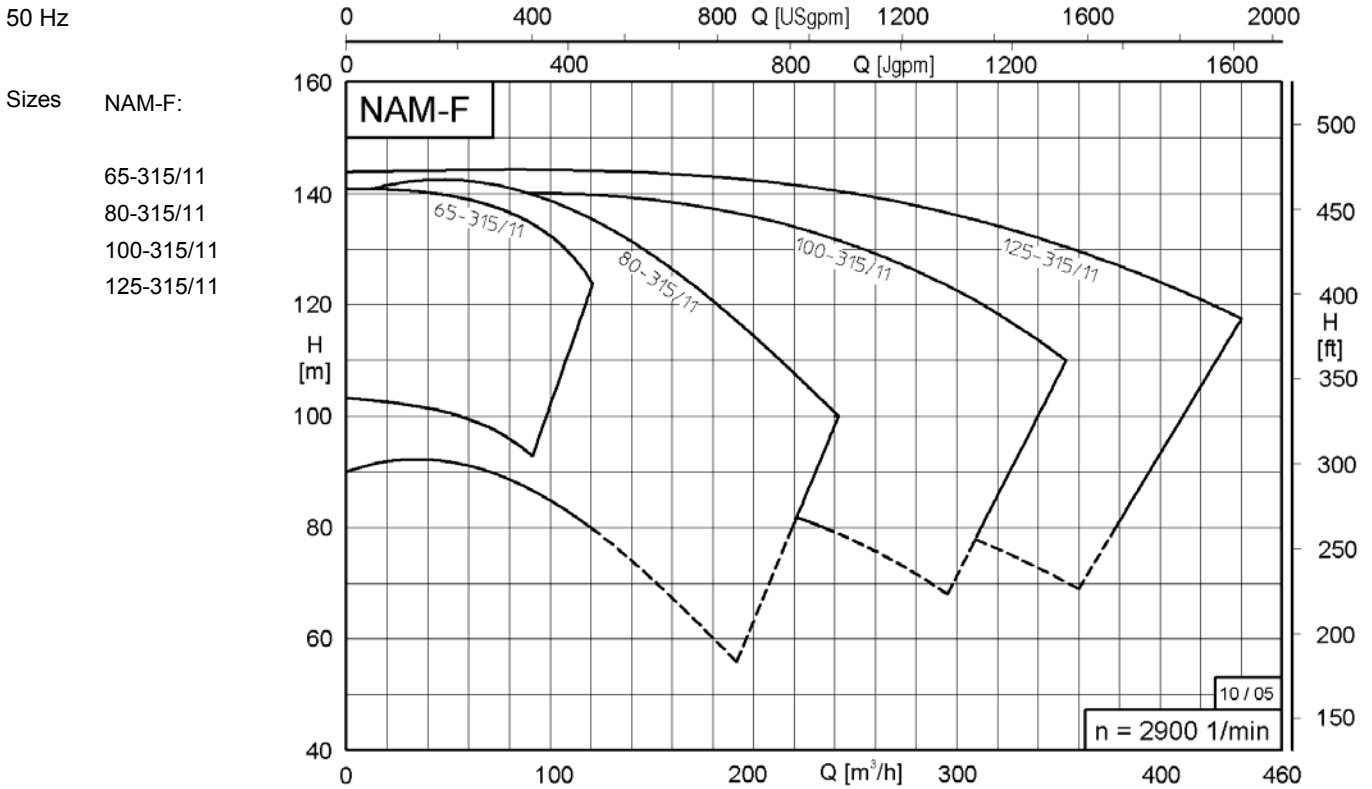

Valid for $\rho = 1 \text{ kg/dm}^3$ and $\nu = 1 \text{ mm}^2/\text{s}$.

Exact performance data to be taken from the selection programme ALLSELECT.

Selection may be restricted by NPSH specification. For delivery heads under 80 m see the standard programme.

View Wall mounting design

List of components for pedestal and wall mounting

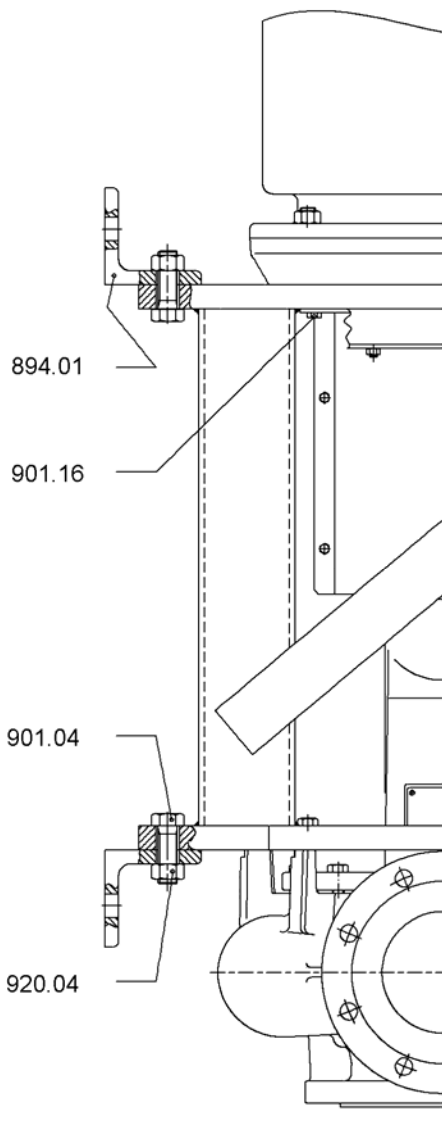

Denomination	Part-No.	Denomination	Part-No.
Volute casing	102.01	Pipe	710.02
Casing cover	161.05	Screwed connection	731.02
Pump foot	182.01	Motor	801.01
Shaft	210.01	Spacer coupling	855.01
Impeller	230.01	Console	894.01
Groove ball bearing	321.01	Hexagon head bolt	901.01
Groove ball bearing	321.02	Hexagon head bolt	901.03
Groove ball bearing	321.03	Hexagon head bolt	901.04
Groove ball bearing	321.04	Hexagon head bolt	901.09
Bearing bracket	330.01	Hexagon head bolt	901.16 ②
Pump bracket	346.01	Stud bolt	902.08 ①
Bearing cover	360.01	Stud bolt	902.10
Bearing cover	360.02	Screw plug	903.01
Gasket	400.01	Screw plug	903.03
Seal ring	411.01	Screw plug	903.04
Seal ring	411.03	Setscrew	904.02
Seal ring	411.04	Setscrew	904.03
Seal ring	411.05	Jacking screw	908.01
V-ring	424.02	Hexagon socket screw	914.04
Mechanical seal	433.01	Hexagon socket screw	914.05
Spacer ring	504.01 ①	Hexagon socket screw	914.10
Intermediate ring	509.02	Hexagon nut	920.04
Nilos ring	516.01	Hexagon nut	920.08 ①
Nilos ring	516.02	Hexagon nut	920.10
Spacer sleeve	525.01	Impeller nut	922.01
Spacer disc	551.01	Circlip	932.01
Ball bearing compensating disc	557.01	Circlip	932.10
Rivet	565.01	Spring disc	934.01
Venting	672.01	Spring ring	936.01
Coupling guard	681.01	Key	940.01
Pipe	710.01	Key	940.02
		Nameplate	971.01

① only at bearing bracket 470

② only at bearing bracket 530

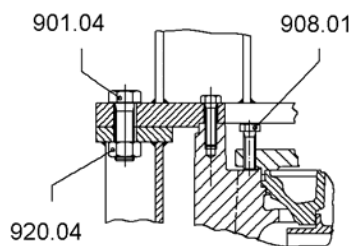

Fastening of pump feet to pump bracket

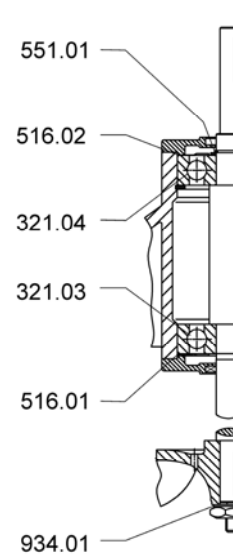

Bearing design and locking of the impeller at bearing bracket size 530

Main dimensions for pedestal mounting

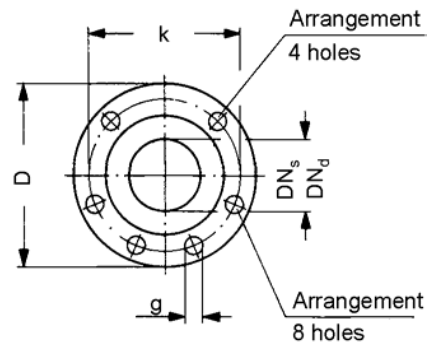
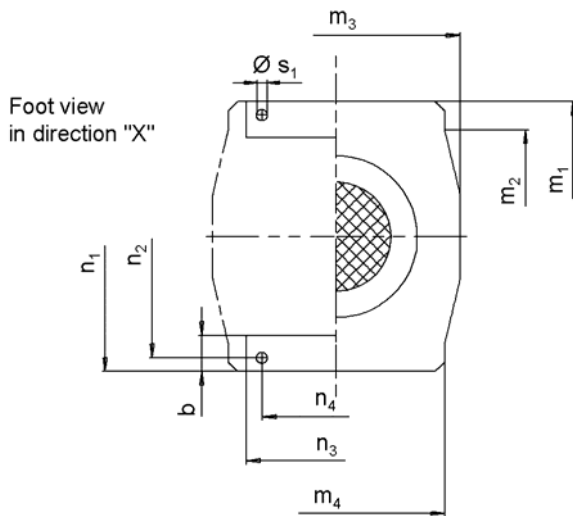
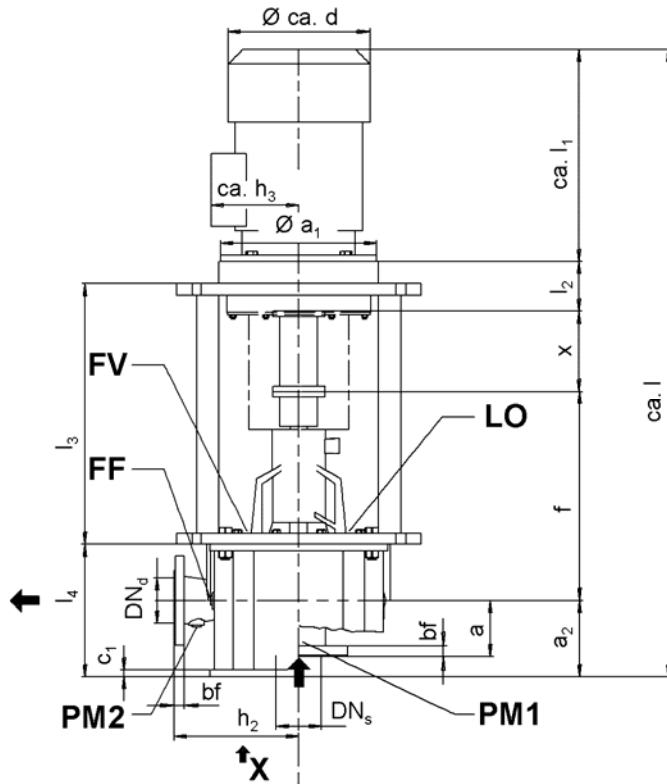

Dimensions in mm.
Sense of rotation: clockwise, as seen from the driving side.

Pump size	Bearing bracket size	Pump bracket size	Dimensions of the pump/motor assembly																			
			Pump dimensions											Extension dimension x	Dimensions of the mounting parts					for screws s ₁		
			DN _s	DN _d	a	a ₂	f	h ₂	l ₃	m ₁	m ₂	m ₃	m ₄		b	c ₁	l ₄	n ₁	n ₂		n ₃	n ₄
65-250/01	470	470-250	80	65	100	170	470	250	587	600	476	550	480	180	80	15	296	600	540	400	330	M20
80-250/01			100	80	125			280														
65-315/11	530	530-315	100	65	125	235	530	280	653	710	540	600	550	180	100	20	355	710	620	500	410	M24
80-315/11			80	315																		
100-250/11			125	280																		
100-315/11			100	315																		
125-250/11			150	125	140			355														
125-315/11								355														

Installation dimensions are available in ALLWEILER drawing archive ALL2CAD.

Main dimensions for wall mounting

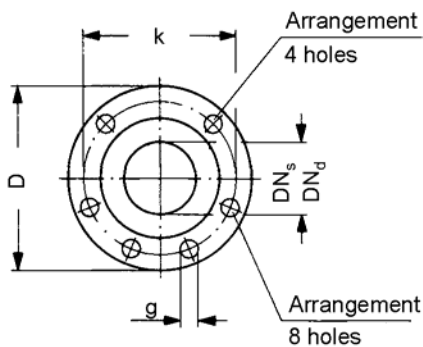
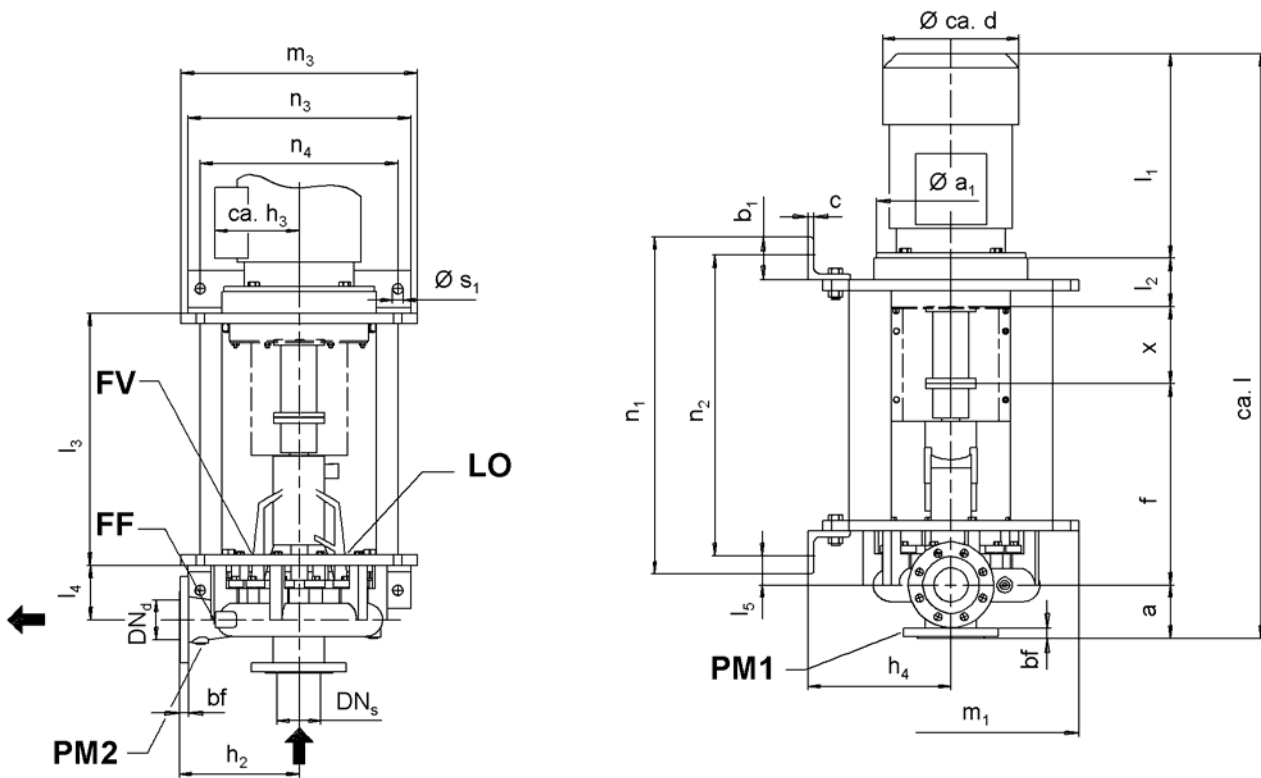

Dimensions in mm.
Sense of rotation: clockwise, as seen from the driving side.

Pump size	Bearing bracket size	Pump bracket size	Dimensions of the pump/motor assembly																		
			Pump dimensions									Extension dimension	Dimensions of the mounting parts								
			DN _s	DN _d	a	f	h ₂	l ₃	l ₄	m ₁	m ₃		x	b ₁	c	h ₄	l ₅	n ₁	n ₂	n ₃	n ₄
65-250/01 80-250/01	470	470-250	80	65	100	470	250	587	126	600	550	180	100	14	335	69	787	702	520	460	M20
100			80	125	280																
65-315/11 80-315/11	530	530-315	100	65	125	530	280	653	120	710	600	180	100	14	370	63	853	767	595	535	M24
100-250/11			80	280																	
100-315/11			100	315																	
125-250/11			140	150	315																
125-315/11					355																

Installation dimensions are available in ALLWEILER drawing archive ALL2CAD.

Flanges

Flanges acc. to EN 1092-2 PN 16					
DN _s / DN _d	D	bf	k	g	No. of holes
65	185	20	145	19	4
80	200	22	160	19	8
100	220	24	180	19	8
125	250	26	210	19	8
150	285	26	240	23	8

Connections

Pump size	Filling	Leakage outlet	Venting		Pressure gauge	
	FF	LO	FV	Automatic aspirator	PM1	PM2
65-250/01	G ³ / ₈	G ³ / ₈	G ¹ / ₂	G ¹ / ₂	G ¹ / ₄	G ³ / ₈
80-250/01						
65-315/11	-	G ³ / ₈	G ¹ / ₂	G ¹ / ₂	G ¹ / ₄	G ³ / ₈
80-315/11						
100-250/11						
100-315/11						
125-250/11						
125-315/11						

Extension possibilities of the insert unit

Pump bracket size	Extension possibility	
	I	II
470-250	yes	yes
530-315	yes	no

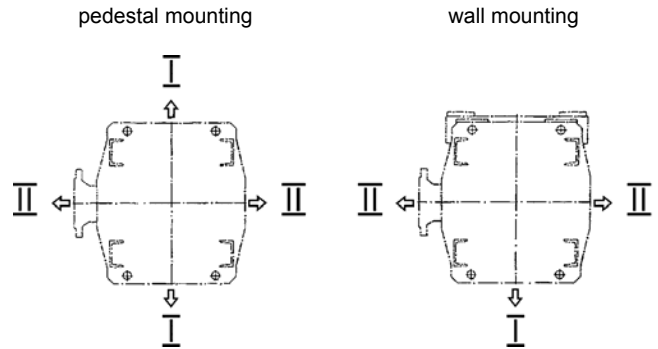

Possible driving motors and the allocation to the pump sizes

The motor dimensions as indicated are approximate values. Exact data depend on the motor make. In case of drive powers of over 132 kW, please inquire in any event as the motor connection dimensions are not standardised.

When using special marine motors, care must be taken that depending upon the degrees of protection different performances are allocated to the individual sizes. The main dimensions are changed accordingly. In case of order, binding motor dimension sheets are to be transmitted to us.

Speed	Motor size	Adapted for mounting on bearing bracket size	kW	a ₁	d	h ₃	l ₁	l ₂	l	Pump size								
										65-250/01	80-250/01	65-315/11	80-315/11	100-250/11	100-315/11	125-250/11	125-315/11	
2900/ 3500 1/min	225 M	470 530	45	450	399	337	667	110	l=a+f+x+l ₂ +11	•	•	•						
	250 M		55		520	430	790	140		•	•	•	•					
	280 S		75	550		575	455			865	•	•	•	•	•	•	•	•
	280 M		90								•	•	•	•	•	•	•	•
	315 S		110								•	•	•	•	•	•	•	•
	315 M	132	530	660	645	515	970							•	•			

Automatic aspirator A 25 A and similar

The A 25 A is employed for the automatic venting of the pump and suction pipe. It operates with a pressure-dependent control system.

Owing to a pressure-controlled stop valve in the suction pipe, the device can also be used in plants in which overpressure is temporarily incurred.

Functioning description

By way of the vent pipe, suction branch Q2 of the automatic aspirator is coupled with connection FV of the pump. The compressed air required for the venting process is supplied to the ejector at connection Q1.

To avoid any dry operation of the pump, the electric circuitry (not included in the normal scope of supply) must be such that the pump is started only after the entire suction system has been vented.

As soon as a discharge pressure has been set up and the preset pressure limit reached, the automatic aspirator is switched off by the pressure switch. The impulse is transmitted by way of the control pressure line coupling connection FF at the pump with connection Q4 at the pressure switch.

The discharge pressure falling below the preset pressure limit, the automatic aspirator will be switched on again.

According to the respective operating conditions, the pressure switch should be adjusted so as to switch the automatic aspirator off at approx. 80 % of the lowest pump discharge pressure, switching it on again at approx. 30 %.

Required control voltage 220 V, 50 Hz or 60 Hz (80 % duty cycle), non-standard voltage upon request. Power consumption during starting 22 VA, during operation 15 VA, degree of protection IP 54.

Materials

Lower nozzle: Synthetic materials

Upper nozzle: Synthetic materials

Inlet nozzle: G-CuZn 16 Si 4

Pipes: ① Cu

① coming into contact with the liquid to be pumped

Driving air required at 6 bar working pressure $Q = 0.28 \text{ m}^3/\text{min}$.
The water-air mixture is drained by way of connection Q3.

List of components for the attachment of the automatic aspirator A 25 A, series NAM-F

Denomination	Part-No.
Seal ring	411.31
Seal ring	411.32
Seal ring	411.34
Reinforcing sleeve	532.01
Reinforcing sleeve	532.04
Reinforcing sleeve	532.05
Reinforcing sleeve	532.06
Automatic aspirator	675.01
Pipe	710.05
Pipe	710.06
Holding device	732.02
Pipe fitting	731.04
Pipe fitting	731.06
Pipe fitting	731.07
Pipe fitting	731.08
Pipe fitting	731.09
Hexagon head bolt	901.20
Hexagon head bolt	901.22
Hexagon nut	920.15
Lock washer	935.04

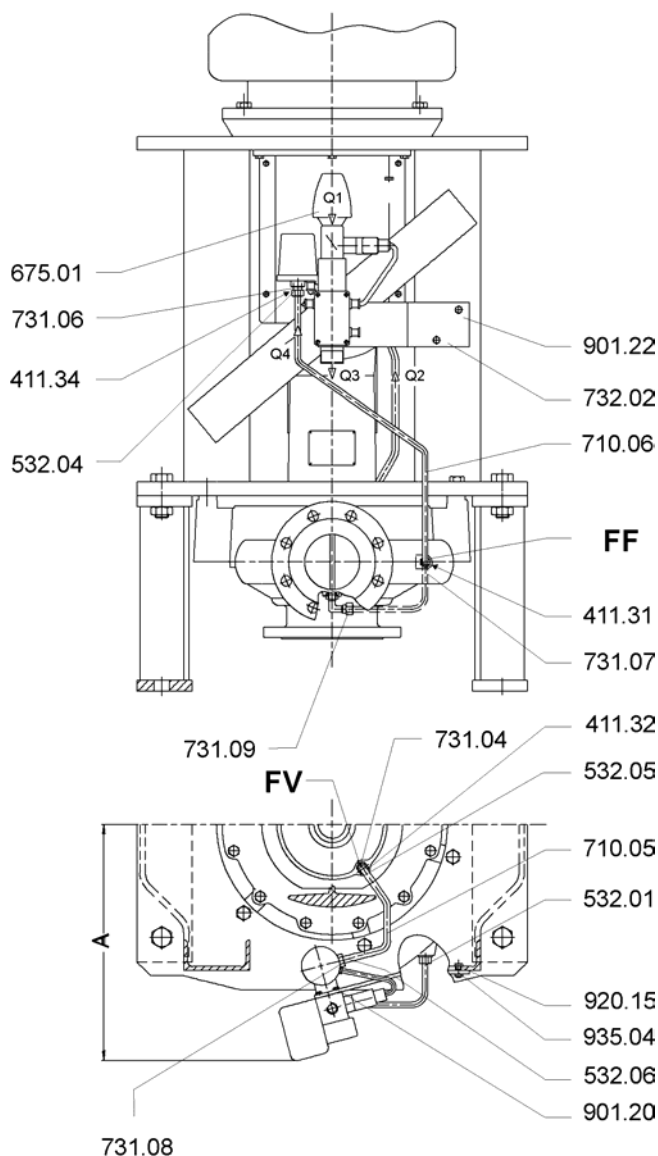

Note: With sizes 65-250/01 and 80-250/01 connection on FF (731.09 not required).

Pump size	Pump bracket size	Dimension A
65-250/01	470-250	400
80-250/01		
65-315/11	530-315	435
80-315/11		
100-250/11		
100-315/11		
125-250/11		
125-315/11		

For further details please refer to the documentation of the automatic aspirator.

Successful in important branches

Decades of experience and branch-specific know-how ensure solutions that are practical and dependable. In addition to individual units with a motor or with a free shaft end, you can get complete systems and customer-specific cast parts from ALLWEILER AG. You are not just investing in machines with ALLWEILER AG. You are also profiting from decades of know-how about applications and processes in your branch.

You will find pumps and systems by ALLWEILER AG in the following sectors:

► **Marine and Offshore**

Made of particularly corrosion-resistant, saltwater-proof materials and in accordance with specific standards (shock testing, national marine, international classifications, etc.).

► **Power Generation**

Block and twin units for fuel and water injection in gas and steam turbines.

For fuel supply, injection and lubricating oil delivery in power plants.

► **Water and Wastewater**

Pumps for water treatment; share of dry solids content up to 45 %; macerators, which make it possible to pump delivery media that are high in fibre and solids.

► **Biofuels**

Materials resistant to aggressive intermediate and final products. Pumps for every step in the process.

► **Process Engineering and Chemistry (ATEX-conformity)**

Shaft bearing, shaft seal and material designs in accordance with the chemical characteristics of the delivery media. Magnetic coupling for hermetically sealed pumps.

► **Oil and Gas**

Pumps with a wide viscosity range, high pressure and large capacity.

► **Building Industry**

Special units for oil furnace and lift systems. Oil submersible pumps for all types of hydraulic machines.

► **Food and Pharma**

Stainless steel pumps with CIP and SIP design, EHEDG and FDA certified. Especially for the careful delivery and proportioning of even sticky, paste-like and solids-rich media.

► **Tool Machinery**

Designed for large capacity or a high discharge pressure; resistant to contaminants and foreign materials. Especially for cooling lubricant supply.

► **Pulp and Paper**

Pumps with extremely high availability (24 hours; 365 days) and many sizes, starting with small proportioning pumps and ranging to large Kaolin feeding pumps.

► **Heat Transfer**

In supply circuits, circulating systems and heating circuits for the delivery of hot water and heat-transfer oil up to 207 °C and 450 °C.

Subject to technical alterations.

ALLWEILER 
A Colfax Business Unit

ALLWEILER AG
Postfach 1140 · 78301 Radolfzell
Allweilerstr. 1 · 78315 Radolfzell
Germany
Tel. +49 (0)7732 86-0
Fax. + 49 (0)7732 86-436
E-Mail: service@allweiler.de
Internet: <http://www.allweiler.com>

The mentioned performance data and additionally all standard references are to be considered as a product and performance abstract only. The particular operating limits can be taken from the quotation or order acknowledgement.